

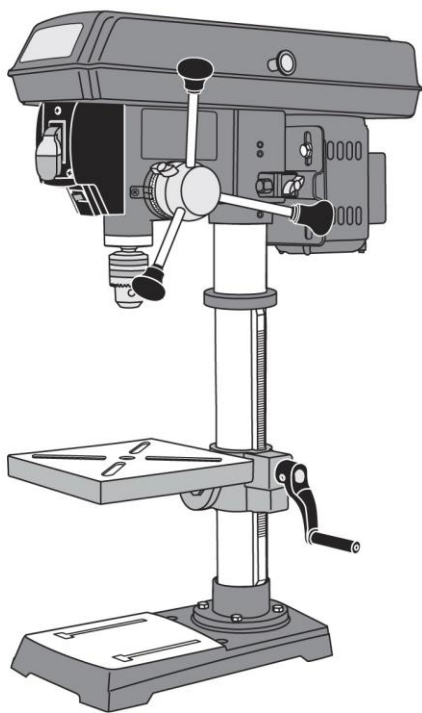

**10" Drill Press  
With Laser Crosshair**



**Questions? Problems?  
Please call our customer help line:**

**(888) 315-3080 M-F 8-5 CST**

**SKU: 240-3706**

**Operation and Safety Instructions**

## **Table of Contents**

Technical data.....	2
General safety rules.....	3
Specific safety rules for drill presses.....	5
Electrical information.....	6
Know your drill press.....	8
Assembly and adjustments.....	9
Operation.....	21
Maintenance.....	25
Exploded view.....	26
Parts list.....	27
Warranty.....	28

## **Technical data**

10" Drill Press with Laser Crosshair	SKU: 240-3706
Motor:	120 V, 60 Hz, 3.2 A
Horsepower:	1/3 HP (single phase)
Motor speed:	1700 RPM (no load)
Drilling capacity:	2-1/4" (5.7 cm)
Chuck capacity:	0-1/2" (0-13 mm)
Pulley speeds:	5 (570, 900, 1390, 2050, 3050 RPM)
Table size:	7-5/8" x 7-5/8" (19.4 x 19.4 cm)
Chuck to table:	9-3/8" (33 cm) – maximum capacity
Laser module:	Class II
Laser wavelength:	660 nm
Laser output:	1 mW
Overall height:	28-1/4" (71.8 cm)
Weight:	55 lb (25 kg)

## **General safety rules**

Safety is a combination of common sense, staying alert, and knowing how your drill press works. **SAVE THESE SAFETY INSTRUCTIONS.**



**WARNING:** To avoid mistakes that could cause serious injury, do not plug in the drill press until the following steps have been read and understood.

1. **READ** and become familiar with this entire instruction manual. **LEARN** the tool's applications, limitations, and possible hazards.
2. **AVOID DANGEROUS CONDITIONS.** Do not use power tools in wet or damp areas or expose them to rain. Keep work areas well-lit.
3. **DO NOT** use power tools in the presence of flammable liquids or gases.
4. **ALWAYS** keep your work area clean, uncluttered, and well-lit. **DO NOT** work on floor surfaces that are slippery with sawdust or wax.
5. **KEEP BYSTANDERS AT A SAFE DISTANCE** from the work area, especially when the tool is operating. **NEVER** allow children or pets near the tool.
6. **DO NOT FORCE THE TOOL** to do a job for which it was not designed.
7. **DRESS FOR SAFETY.** Do not wear loose clothing, gloves, neckties, or jewelry (rings, watches, etc.) when operating the tool. Inappropriate clothing and items can get caught in moving parts and draw you in. **ALWAYS** wear non-slip footwear and tie back long hair.
8. **WEAR A FACE MASK OR DUST MASK** as the drilling operation produces dust.



**WARNING:** Dust generated from certain materials can be hazardous to your health. Always operate the drill press in a well-ventilated area and provide for proper dust removal. Use dust collection systems whenever possible.

9. **ALWAYS** remove the power cord plug from the electric outlet when making adjustments, changing parts, cleaning or working on the tool.
10. **KEEP GUARDS IN PLACE AND IN WORKING ORDER.**
11. **AVOID ACCIDENTAL START-UPS.** Make sure the power switch is in the OFF position before plugging in the power cord.
12. **REMOVE ADJUSTMENT TOOLS.** Always make sure all adjustment tools are removed from the drill press before turning it on.

## **General safety rules (continued)**

13. NEVER LEAVE A RUNNING TOOL UNATTENDED. Turn the power switch to OFF. Do not leave the tool until it has come to a complete stop.
14. NEVER STAND ON A TOOL. Serious injury could result if the tool tips or is accidentally hit. DO NOT store anything above or near the tool.
15. DO NOT OVERREACH. Keep proper footing and balance at all times. Wear oil-resistant rubber-soled footwear. Keep the floor clear of oil, scrap, and other debris.
16. MAINTAIN TOOLS PROPERLY. ALWAYS keep tools clean and in good working order. Follow instructions for lubricating and changing accessories.
17. CHECK FOR DAMAGED PARTS. Check for alignment of moving parts, jamming, breakage, improper mounting, or any other conditions that may affect the tool's operation. Any part that is damaged should be properly repaired or replaced before use.
18. MAKE THE WORKSHOP CHILDPROOF. Use padlocks and master switches and ALWAYS remove starter keys.
19. DO NOT operate the tool if you are under the influence of drugs, alcohol, or medication that could affect your ability to use the tool properly.
20. USE SAFETY GOGGLES AT ALL TIMES—that comply with ANSI Z87.1. Normal safety glasses only have impact resistant lenses and are not designed for safety. Wear a face or dust mask when working in a dusty environment. Use ear protection, such as plugs or muffs, during extended periods of operation.



## **Laser safety**

1. Do not stare directly at the laser beam. Eye damage may occur if you deliberately stare into the beam.
2. The laser light beam used in this system is Class II with maximum 1 mW and 660 nm wavelengths. AVOID DIRECT EYE EXPOSURE.
3. The laser must be used and maintained in accordance with the manufacturer's instructions:
  - Never aim the beam at any person or an object other than the workpiece.
  - Do not project the laser beam into the eyes of others.
  - Always ensure the laser beam is aimed at a workpiece without reflective surfaces as the laser beam could be projected into your eyes or the eyes of others.

 **AVOID EXPOSURE** - Laser radiation is emitted from this aperture.

**EVITE LA EXPOSICIÓN** - Desde esta abertura se emite radiación láser.

**ÉVITER L'EXPOSITION** - Des rayons laser sortent de cette ouverture.

**DANGER**

**DANGER – LASER RADIATION** – Do not stare into beam.

**DANGER – RADIACIÓN LÁSER** – No se exponga los ojos a los rayos.

**DANGER – RAYONNEMENT LASER** – Ne pas plonger les yeux dans le faisceau.

 5 mW MAX at 635 nm.  
Class III A Laser Product.  
Complies with 21 CFR 1002.12.

## **Specific safety rules for drill presses**



**WARNING:** Do not operate your drill press until it is completely assembled and installed according to the instructions.

1. Never turn on the drill press before clearing the table of all objects (tools, scraps, etc.).
2. Always keep hands and fingers away from the drill bit.
3. Do not drill material that does not have a flat surface, unless a suitable support is used.
4. Never start the drill press with the drill bit pressed against the workpiece.
5. Make sure the table lock is tightened before starting the machine.
6. Never perform layout, assembly, or set-up work on the table while the drill is in use.
7. Make sure drill bit is securely locked in the chuck.
8. Make sure chuck key is removed from the chuck before turning power on.
9. Adjust the table or depth stop to avoid drilling into the table.
10. Always stop the drill before removing scrap pieces from the table.
11. Use clamps or a vise to secure workpiece to the table. This will prevent workpiece from rotating with the drill bit.
12. Do not wear gloves when operating a drill press.
13. Shut the power off, remove the drill bit, and clean the table before leaving the drill press.
14. Set the drill press to the speed appropriate for the job.
15. Should any part of your drill press be missing, damaged, or any electrical component fail to perform properly, shut power off and unplug the drill press. Replace missing, damaged, or failed parts before resuming operation.

## **Electrical information**

### **Grounding instructions**

IN THE EVENT OF A MALFUNCTION OR BREAKDOWN, grounding provides the path of least resistance for electric current and reduces the risk of electric shock. This tool is equipped with an electric cord that has an equipment grounding conductor and a grounding plug. The plug **MUST** be plugged into a matching outlet that is properly installed and grounded in accordance with **ALL** local codes and ordinances.

**DO NOT MODIFY THE PLUG PROVIDED.** If it will not fit the outlet, have the proper outlet installed by a licensed electrician.

**IMPROPER CONNECTION** of the equipment grounding conductor can result in electric shock. The conductor with the green insulation (with or without yellow stripes) is the equipment grounding conductor. If repair or replacement of the electric cord or plug is necessary, **DO NOT** connect the equipment grounding conductor to a live terminal.

**CHECK** with a licensed electrician or service personnel if you do not completely understand the grounding instructions, or if you are not sure if the tool is properly grounded.

**USE ONLY THREE-WIRE EXTENSION CORDS** that have 3-pronged plugs and outlets that accept the tool's plug as shown in Fig. A. Repair or replace a damaged or worn cord immediately.

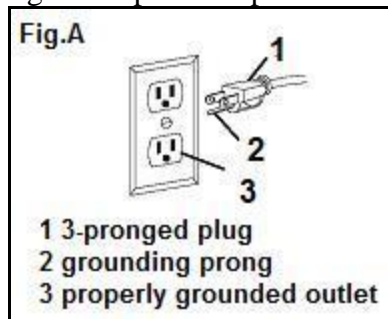

**CAUTION:** In all cases, make certain the outlet in question is properly grounded. If you are not sure if it is, have a licensed electrician check the outlet.

## Electrical information (continued)



**WARNING:** This drill press is for indoor use only. Do not expose to rain or use in damp locations.

### **Guidelines for using extension cords**

Make sure your extension cord is in good condition. When using an extension cord, be sure to use one heavy enough to carry the current your product will draw. An undersized cord will cause a drop in line voltage resulting in loss of power and overheating. The table below shows the correct size to be used according to cord length and nameplate ampere rating. If in doubt, use the next heavier gauge. The smaller the gauge number, the heavier the cord.

**Minimum Gauge for Extension Cords (AWG)**  
(When using 120 V only)

Ampere Rating		Total Length of Cord in feet			
More Than	Not More Than	25	50	100	150
0	6	18	16	16	14
6	10	18	16	14	12
10	12	16	16	14	12
12	16	14	12	Not Recommended	

Make sure your extension cord is properly wired and in good condition. Always replace a damaged extension cord or have it repaired by a qualified person before using it.

Protect your extension cords from sharp objects, excessive heat and damp or wet areas.

Use a separate electrical circuit for your tools. This circuit must not be less than a #12 wire and should be protected with a 15 A time-delayed fuse. Before connecting the motor to the power line, make sure the switch is in the OFF position and the electric current is rated the same as the current stamped on the motor nameplate. Running at a lower voltage will damage the motor.



**WARNING:** This tool must be grounded while in use to protect the operator from electric shock.

# Know your drill press

Fig. 1

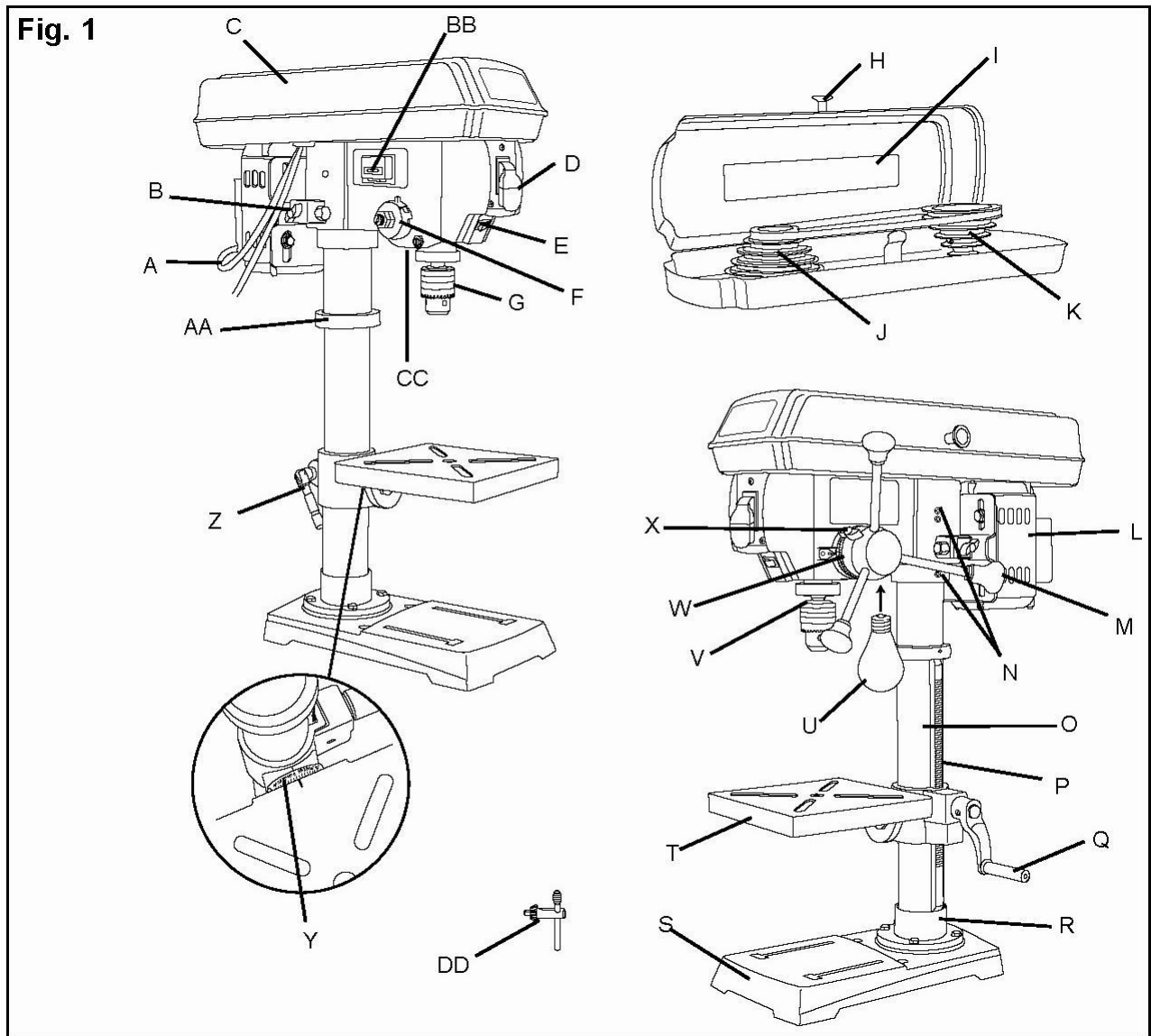

- |   |                              |   |                |    |                          |
|---|------------------------------|---|----------------|----|--------------------------|
| A | Power cord                   | K | Motor pulley   | U  | Light bulb(not provided) |
| B | Tension lock knob            | L | Motor          | V  | Quill                    |
| C | Pulley housing cover         | M | Feed handle    | W  | Depth scale              |
| D | On/off switch                | N | Locking screw  | X  | Depth tension knob       |
| E | Light switch                 | O | Column         | Y  | Bevel scale              |
| F | Feed return spring and cover | P | Rack           | Z  | Support lock handle      |
| G | Chuck                        | Q | Crank handle   | AA | Rack collar              |
| H | Pulley housing knob          | R | Column support | BB | Laser switch             |
| I | Belt/pulley speed chart      | S | Base           | CC | Laser light (2)          |
| J | Spindle pulley               | T | Table          | DD | Chuck key                |



## Assembly and adjustments

### Unpacking (Fig. 2)

Unpack the drill press and all its parts, and compare against the list below. Do not discard the carton or any packaging until the drill press is completely assembled.

To protect the drill press from moisture, a protective coating has been applied to the machined surfaces. Remove this coating with a soft cloth moistened with kerosene or WD-40®. Do not use acetone, gasoline, or lacquer thinner to clean. Apply a coat of good paste wax to the table and column. Wipe all parts with a clean dry cloth.

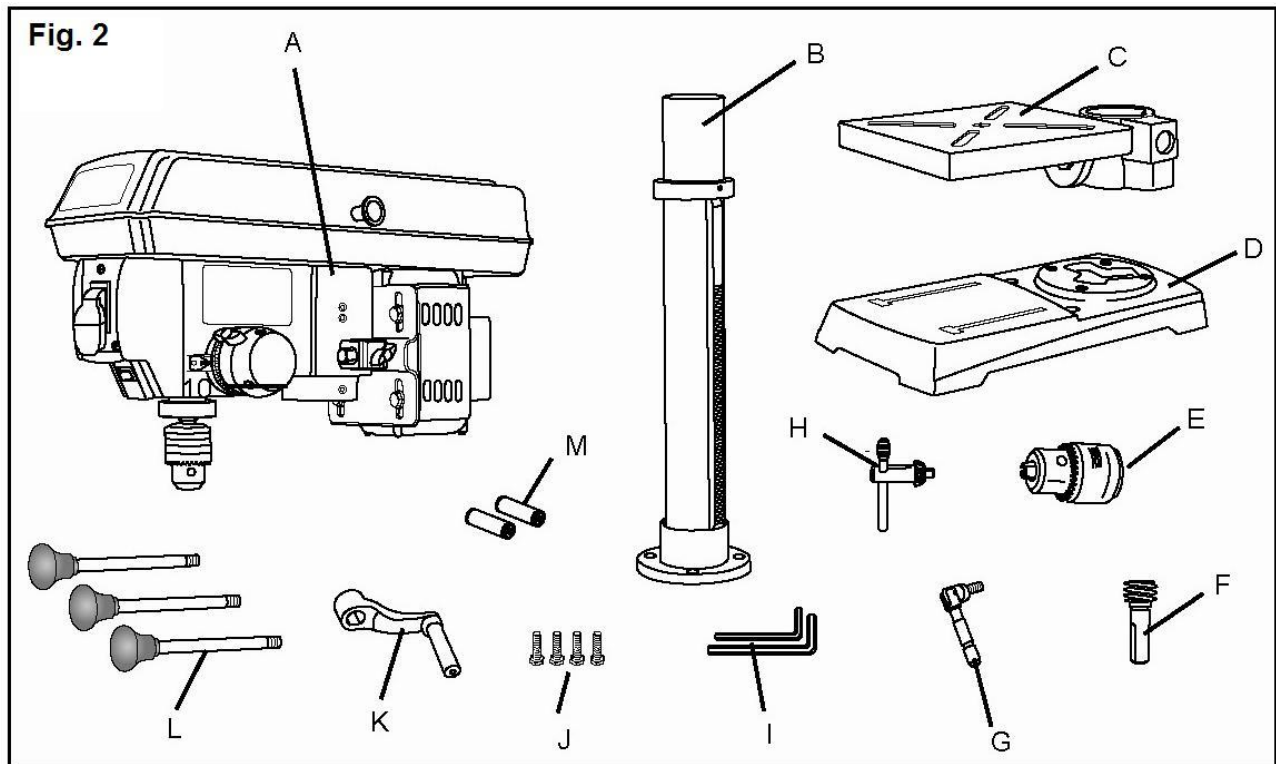

- A Head/motor assembly
- B Column assembly
- C Table
- D Base
- E Chuck
- F Worm shaft
- G Lock handle

- H Chuck key
- I Allen wrench (2)
- J Hex head bolts (4)
- K Crank handle
- L Feed handles (3)
- M "AA" batteries (2)

## Assembly and adjustments (continued)

### Tools needed for assembly

- Adjustable wrench
- Phillips® screwdriver
- Hammer and block of wood

### Base to column (Fig. 3)

1. Set the base (1) on the floor.
2. Place the column tube (2) on the base (1), align the column support holes with the base holes.
3. Install a bolt (3) in each column support hole and tighten with the wrench.

### Table to column (Fig. 4–7)

1. Loosen set screw (2) in rack collar (1) and remove the collar.
2. Remove the rack (3) from the column (4).
3. Insert worm shaft (5) into the hole of the table support crank handle (6) from inside the table support. The worm shaft (5) should extend outside the housing about 1” (25 mm).
4. Insert the rack (3) into the geared groove of the table support (6). Make sure the worm shaft (5) on the inside of the table support is engaged with the teeth of the rack. The table support should sit at the center of the rack.
5. Slide the table support and rack assembly (3, 5, and 6) down together onto the column. Insert the bottom edge of the rack into the lip (7) of the column support. Hold in this position until step 6 is completed.

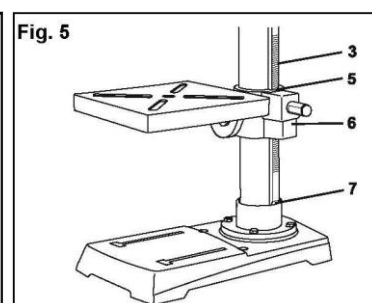
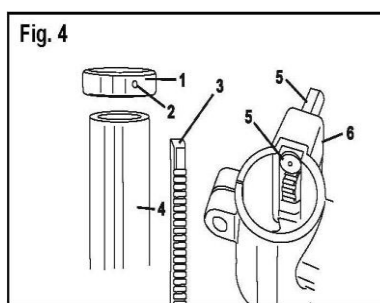
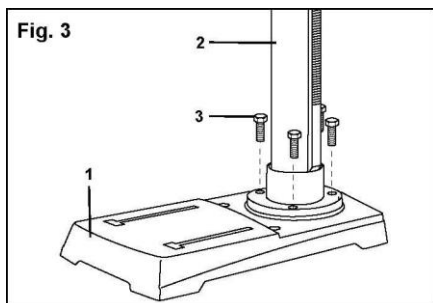

## Assembly and adjustments (continued)

6. Place the collar (1) bevel side down over the rack. Tighten the set screw (2) with the 3 mm Allen wrench to hold the rack in position.

**Note:** Make sure there is enough clearance to allow the table to rotate around the column. The collar must sit loosely over rack and not angled on the column. To avoid column or collar damage, only tighten the set screw enough to keep collar in place (Fig. 6).

7. Insert the table support crank handle (9) into the worm gear shaft on the side of the table support (8). Make sure the set screw (10) is aligned on the flat of the shaft and as close to the table support as possible. Tighten the set screw (Fig. 7).

8. Position the table in the same direction as the base, and tighten the column lock handle (11).

### **Drill press head to column (Fig. 8)**

1. Lift the drill press head assembly (1) carefully and place the mounting hole of the drill press head onto the top of the column (2). Make sure the head is seated properly on the column.

2. Align the direction of the drill press head to the direction of the base and the table.

3. Tighten the two set screws (3) using an Allen wrench.

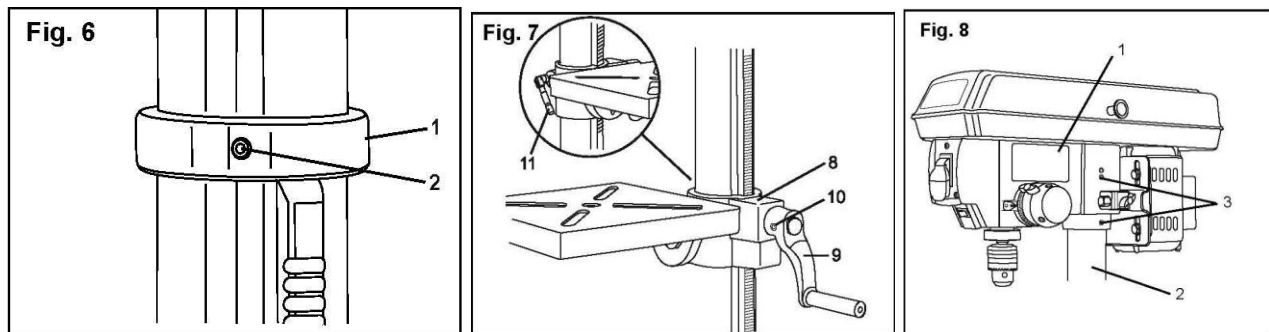

## Assembly and adjustments (continued)

### **Feed handles** (Fig. 9)

1. Thread the three feed handle rods (1) into the holes on the feed hub (2).
2. Hand tighten.

**Note:** One or two of the feed handles may be removed if an unusually-shaped workpiece interferes with handle rotation.

### **Laser batteries** (Fig. 10)

1. Turn off the laser.
2. Press the tab (1) located below the laser switch (2) and lift up the laser switch cover (3).
3. Insert 2 "AA" batteries in the laser battery compartment (4).
4. Close the laser switch cover.

**CAUTION:** Remove the laser light batteries when the tool is to be stored without use for a few days or more. If left in position, the batteries might leak and damage the laser light assembly. Damage due to leaking batteries is not covered under the warranty.

### **Light bulb** (Fig. 11)

Insert the light bulb (1) in the socket (2) in the motor head assembly.

**Note:** The light bulb is optional. Use an appliance-sized bulb similar to those used in a refrigerator or oven. The light bulb is not supplied with the drill press.

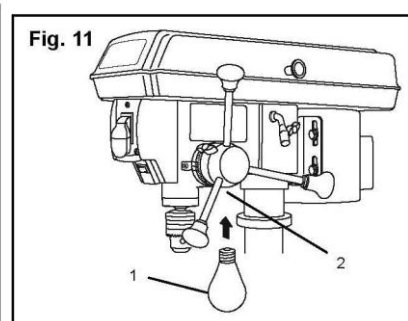
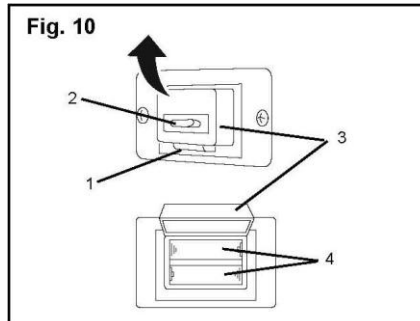
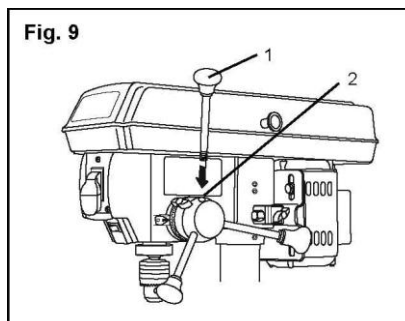

## Assembly and adjustments (continued)

### Mount the drill press (Fig. 12)

Your drill press must be securely fastened through the mounting holes (1) to a stand or work bench with heavy-duty fasteners. This will prevent the drill press from tipping over, sliding, or walking during operation.

**IMPORTANT:** If the stand or workbench has a tendency to move during operation, fasten it securely to the floor.

### Install the chuck (Fig. 13)

1. Inspect and clean the taper hole in the chuck (1) and the spindle (2). Remove all grease, coatings, and particles from the chuck and spindle surfaces with a clean cloth.
2. Open the chuck jaws (3) by turning the chuck barrel clockwise by hand. Make sure the jaws are completely recessed inside the chuck.
3. Seat the chuck on the spindle by placing a block of wood (4) under the chuck (1) and tapping the wood with a hammer (5) or tap the chuck with a rubber mallet.

**CAUTION:** To avoid damaging the chuck, make sure the jaws are completely recessed into the chuck. Do not use a metal hammer directly to drive the chuck into the spindle.

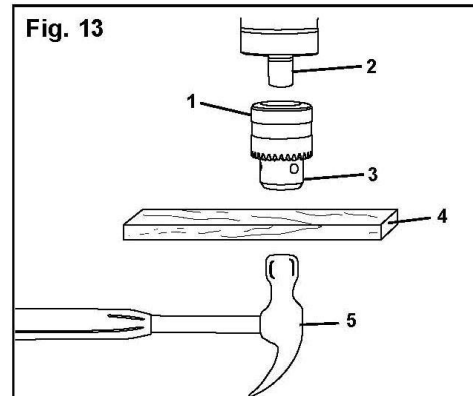
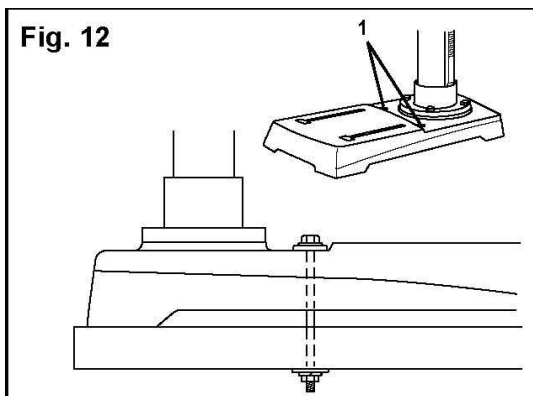

## Assembly and adjustments (continued)

### **Remove the chuck** (Fig. 14)

1. Turn the feed handles (1) to lower the chuck (2) to the lowest position.
2. Place a ball joint separator (not shown) above the chuck (3) and tap it lightly with a hammer (4) to cause the chuck to drop from the spindle.

**Note:** To avoid possible damage, be prepared to catch the chuck as it falls.

### **Install the belt** (Fig. 15)

1. Open the pulley and belt cover (1).
2. Loosen the belt tension lock knobs (2) on both sides of the drill press.
3. Slide the motor (3) as close to the drill press head as possible.
4. Place a belt (4) on the motor pulley (5) and the spindle pulley (6) in the proper position for the desired speed (see Fig. 17).
5. Pull the motor away from the drill press head until the belt is properly tensioned. Tighten the belt tension lock knobs (2).

**Note:** The belt (4) should be tight enough to prevent slippage. Correct tension is set if the belt flexes about 1/2" (13 mm) when thumb pressure is applied at the midpoint of the belt between the pulleys.

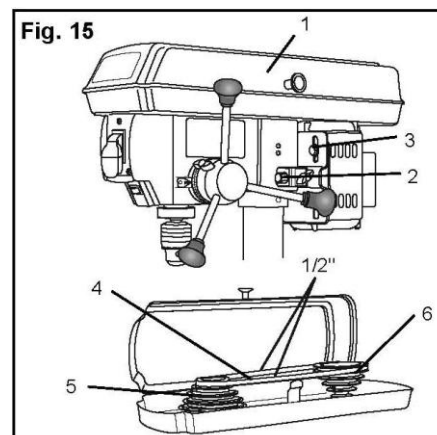
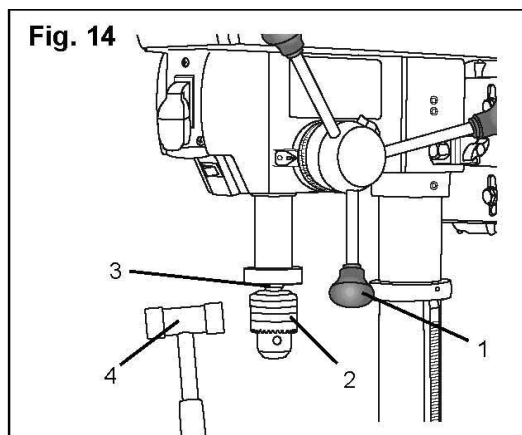

## Assembly and adjustments (continued)

### Adjustments

#### Align the belt pulleys (Fig. 16)

1. Check the alignment of the pulleys with a straight edge (1) (such as a ruler, level, or framing square) by laying the straight edge across the top of the pulleys (2).
2. If the pulleys are not aligned, release belt tension by loosening the belt tension lock knobs (3) on both sides of the head.
3. Loosen the motor mount nuts (4) with an adjustable wrench, and lower or raise the motor until the pulleys are aligned.
4. Tighten the motor mount nuts (4) with an adjustable wrench to maintain the position.
5. Lock the motor for the proper belt tension and tighten the tension lock knobs (3).

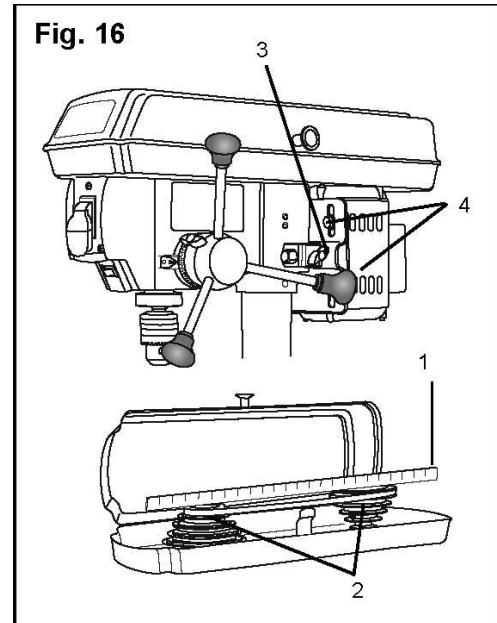

#### Spindle speeds (Fig. 17)

This drill press offers 5 spindle speeds from 570 to 3050 RPM. The highest speed is obtained when the belt is positioned on the largest motor pulley step and the smallest spindle pulley stop.

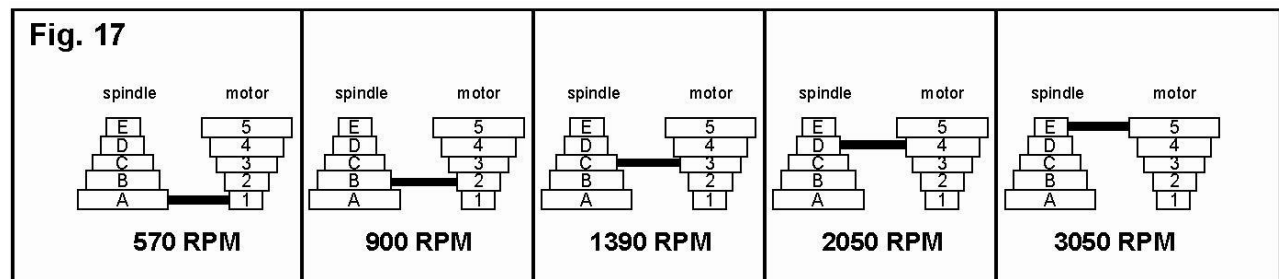

## Assembly and adjustments (continued)



**WARNING:** Disconnect the drill press from the power source before making any speed adjustments.

### **Adjust speeds and tension the belt (Fig. 18)**

1. Open the drill press pulley cover (1).
2. Loosen the belt tension knobs (2) on both sides of the drill press head.
3. Pull the motor (3) toward the drill press head.
4. Set the belt on the desired steps of the motor (4) and spindle (5) pulleys according to the belt positions on the spindle speed chart (Fig. 17).
5. Pull the motor away from the drill press head to increase the belt tension. Tighten the tension knobs (2).
6. The belt (4) should be tight enough to prevent slippage. Correct tension is set if the belt flexes about 1/2" (13 mm) when thumb pressure is applied at the midpoint of the belt between the pulleys.

### **Table adjustments**

#### **Raise or lower the table (Fig. 19)**

1. Raise or lower the table by loosening the column lock handle (1) and turning the crank handle (2) until the table is at the desired height.
2. Tighten the table lock handle (1) before drilling.
3. Rotate the table around the column by loosening the column lock handle (1) and turning the table around the column to the desired position.
4. Tighten the lock handle before drilling.

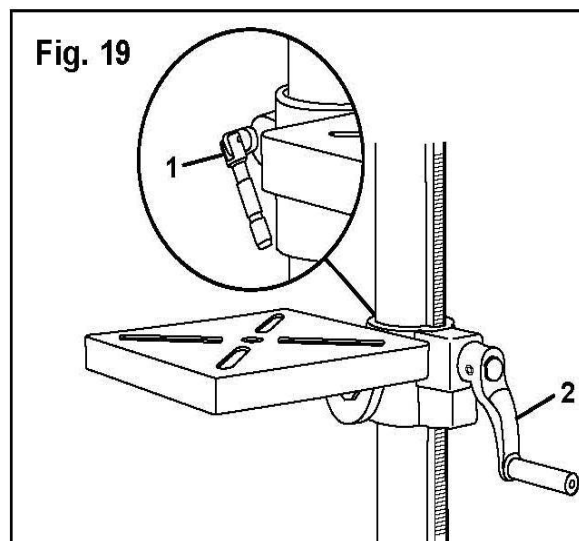
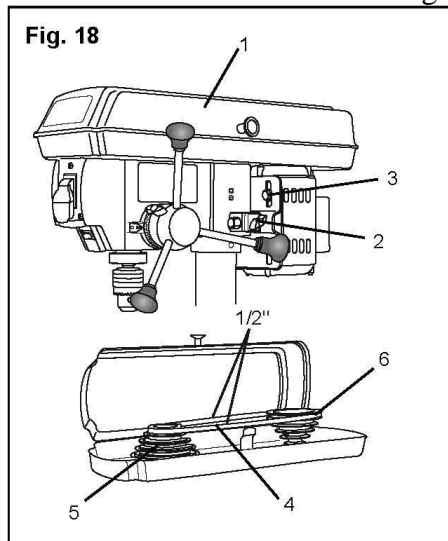



## Assembly and adjustments (continued)

### **Tilt the table** (Fig. 20)

The table can be tilted from 0 to 45° to the left and right.

1. Loosen the bevel lock bolt (1) with a wrench.
2. Tilt the table (2) to the desired angle, using the bevel scale (3) as a basic guide.
3. Re-tighten the bevel lock bolt (1).
4. To return the table to its original position, loosen the bevel lock bolt. Realign the bevel scale (2) to the 0° setting.
5. Tighten the bevel lock bolt (1) with the wrench.

### **Square the table to the head** (Fig. 21)

1. Insert a 3" (7.6 cm) drill bit (1) into the chuck (2) and tighten.
2. Raise and lock the table (3) about 1" (2.5 cm) from the end of the drill bit.
3. Place a combination square (4) on the table as shown. The drill bit should be parallel to the straight edge of the square.
4. If an adjustment is needed, loosen the bevel lock (5) with a wrench.
5. Square the table to the bit by tilting the table.
6. Tighten the bevel lock bolt (5) when square.

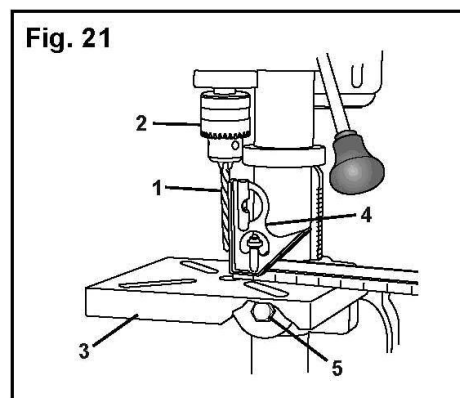
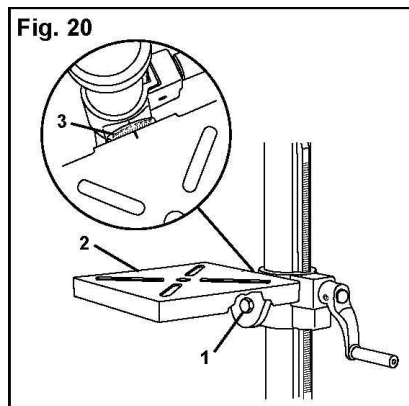

## Assembly and adjustments (continued)

### **Drilling depth** (Fig. 22)

1. To stop the drill at a specific depth for consistent and repetitive drilling, loosen the depth scale lock (1) located on the depth scale hub (2).
2. Turn the hub until the pointer (3) is aligned to the desired depth on the scale.
3. Tighten the depth scale lock (1). The chuck will stop after traveling downward to the distance selected.

**Note:** All the necessary adjustments for the working of your drill press have been done at the factory. Please do not modify them. However, because of normal wear and tear of your tool, some readjustments might be necessary.

### **Spindle return spring** (Fig. 23)

The spindle is equipped with an auto-return mechanism. The main components are a spring and a notched housing. The spring was properly adjusted at the factory and should not be readjusted unless absolutely necessary. If it needs to be adjusted, proceed as follows:

1. Unplug the drill press.
2. Place a screwdriver into the loop (1) to hold the spring in place.
3. Loosen the two housing nuts (2) approximately 1/4" (6 mm). Do not remove the nuts from the threaded shaft.
4. While firmly holding the spring housing (3), carefully pull it out until it clears the raised notch (4). Turn it until the next notch (5) is engaged with the raised notch (to increase the tension, turn it counterclockwise; to decrease the tension, turn it clockwise). Tighten the two housing nuts.

**IMPORTANT!** Do not overtighten the two nuts. If the nuts are tightened too much, the movement of the spindle and feed handles will be sluggish.

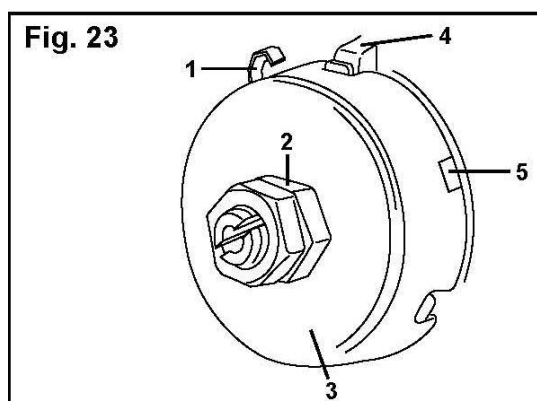
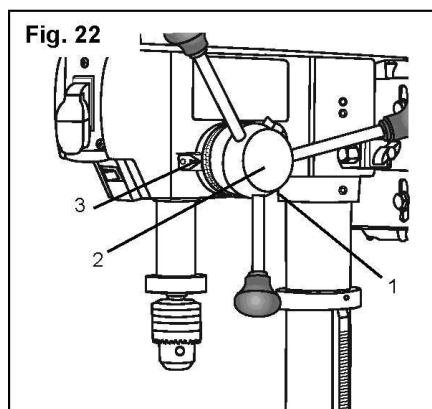

## Assembly and adjustments (continued)

### **Angular play of the spindle** (Fig. 24)

Move the spindle to the lowest downward position and hold in place. With your other hand, try to make it revolve around its axis with a side motion. If there is too much play proceed as follows:

1. Loosen the lock nut (1).
2. Turn the screw (2) clockwise to eliminate the play but without obstructing the upward and downward motion of the spindle (a little bit of play is normal).
3. Tighten the lock nut (1).

### **Install drill bits** (Fig. 25)

1. Place the chuck key (1) into the side keyhole of the chuck (2), meshing the gear teeth (3).
2. Turn the chuck key counterclockwise to open the chuck jaws (4).
3. Insert a drill bit into the chuck far enough to obtain maximum gripping of the chuck jaws.
4. Center the drill bit in the chuck jaws before final tightening of the chuck.
5. Use the chuck key for the final tightening to make sure the drill bit will not slip while drilling.



**WARNING:** To avoid injury, make sure the chuck key is removed from the chuck before starting any drilling operation.

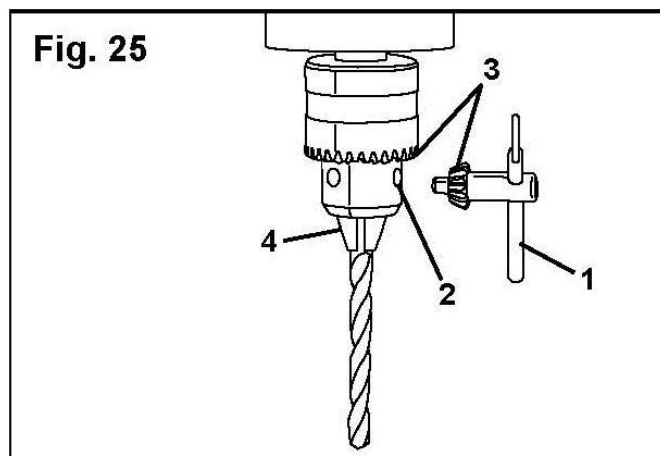
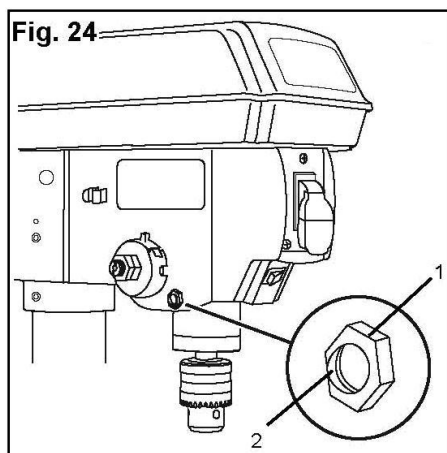

## Assembly and adjustments (continued)



**WARNING: DO NOT STARE DIRECTLY AT THE LASER BEAM!** A hazard may exist if you deliberately stare into the beam. Please observe all safety rules as follows:

- ◆ The laser shall be used and maintained in accordance with the manufacturer's instructions.
- ◆ Never aim the beam at any person or an object other than the workpiece.
- ◆ Do not project the laser beam into the eyes of others.
- ◆ Always ensure the laser beam is aimed at a workpiece with out reflective surfaces as the laser beam could be projected into your eyes or the eyes of others.

### **Laser switch** (Fig. 26)

The laser switch (1) is located on the left side of the drill press housing.

### **Adjust the laser line** (Fig. 26 and 27)

1. Place a workpiece on the table.
2. Turn the laser switch (1) to the ON position.
3. Lower the drill bit to meet the workpiece (2). The two laser lines should cross where the drill meets the workpiece.
4. If the laser needs to be adjusted:
  1. Using a 3 mm hex wrench, turn the laser adjustment hex screws (3) counterclockwise.
  2. Move the laser light housing (4) until the two lines intersect where the drill meets the workpiece. **DO NOT** stare directly at the laser lines.
5. Re-tighten the adjustment hex screws (3).

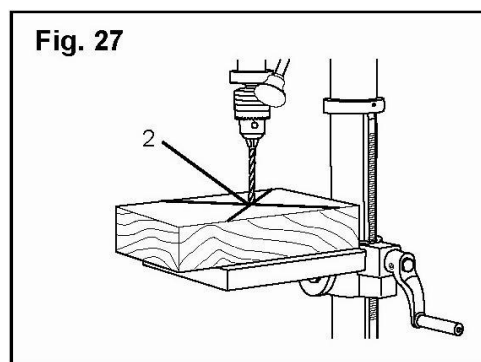
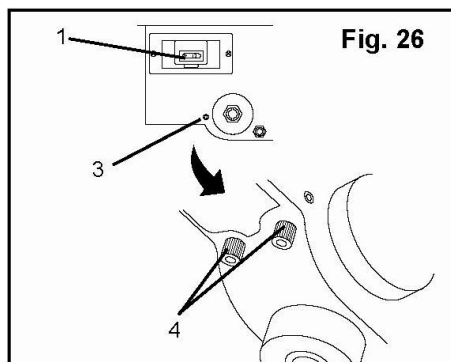

## Operation

### Switches (Fig. 28)

1. To turn the drill press ON, insert the safety key (1) into the switch housing (2). As a safety feature, the switch cannot be turned ON without the key.
2. Flip the switch upward to the ON position.
3. To turn the drill press OFF, move the switch to the down position.
4. To lock the switch in the OFF position, remove the safety key from the switch. Store the key in a safe place.
5. Press the light switch (3) to the ON position to turn on the light.

### Position the table and workpiece (Fig. 29)

Always place a piece of backup material (1) (wood, plywood, etc.) on the table underneath the workpiece (2). This will prevent splintering on the underside of the workpiece as the drill bit breaks through. To keep the material from spinning out of control, it must contact the left side of the column as illustrated, or be clamped to the table.

**Note:** For small workpieces that cannot be clamped to the table, use a drill press vise (optional accessory, not included). The vise must be clamped or bolted to the table to avoid injury.



**WARNING:** To prevent the workpiece and the backup material from being torn from your hand while drilling, position them to the left side of the column. If the workpiece and the backup material are not long enough to reach the column, clamp them to the table. Failure to do this could result in personal injury.

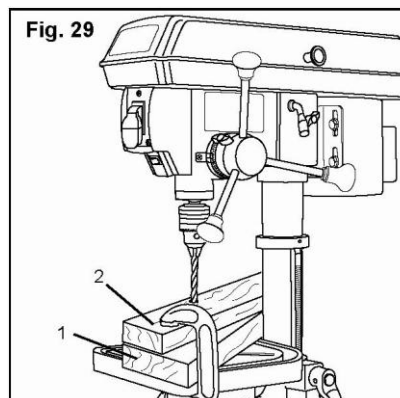
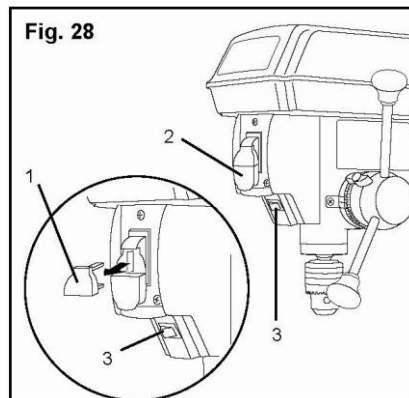

## Operation (continued)



**WARNING:** To avoid injury, make sure the chuck key is removed from the chuck before starting any drilling operation.

### **Drilling a hole**

Use a center punch or sharp nail to dent the workpiece where you want the hole. With the switch OFF, bring the drill bit down to the workpiece, lining it up with the location of the hole. Turn the switch ON and pull down on the feed handles with only enough effort to allow the drill to cut.

- Feeding too slowly might cause the drill bit to turn.
- Feeding too rapidly might stop the motor, causing the belt or drill to slip, tearing the workpiece loose, or breaking the drill bit.
- For deeper cuts, drill into the workpiece about 1/4" (6 mm) and raise the drill bit out of the workpiece. This will clear chips out of the hole. Drill again another 1/4" (6 mm) and raise the drill bit out of the hole to clear debris and chips. Repeat until finished drilling the hole.

Practice with scrap material to get the feel of the machine before attempting to do any regular drilling operation.

When drilling metal, it will be necessary to lubricate the tip of the drill with oil to prevent overheating the drill bit.

### **Drilling to a specific depth**

Drilling a blind hole (not all the way through the workpiece) to a given depth can be done in two ways.

#### **Workpiece method** (Fig. 30)

1. Mark the desired depth of the hole on the side of the workpiece (1).
2. With the switch off, bring the drill bit (2) down until the tip is even with the mark.
3. Hold the feed handle at this position.
4. Lock the depth scale lock knob. The chuck and the drill bit will now be stopped at the distance selected on the depth scale.

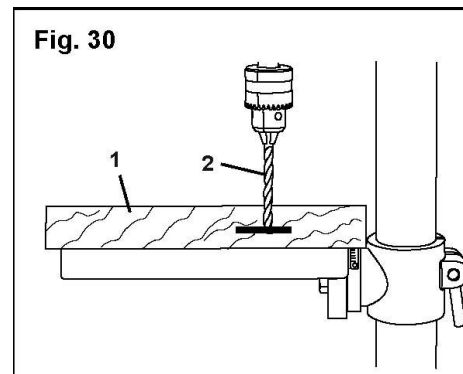

## Operation (continued)

### Depth scale method (Fig. 31)

1. With the switch (1) OFF, turn the feed handle (2) until the drill bit tip (3) slightly touches the top of the workpiece (4).
2. Hold the feed handles in that position.
3. Loosen the depth lock knob (5).
4. Spin the depth scale hub (6) until the desired drilling depth is at the scale pointer.
5. Lock the depth lock knob. The chuck and drill bit will now drill into the workpiece only to the distance selected on the depth scale.

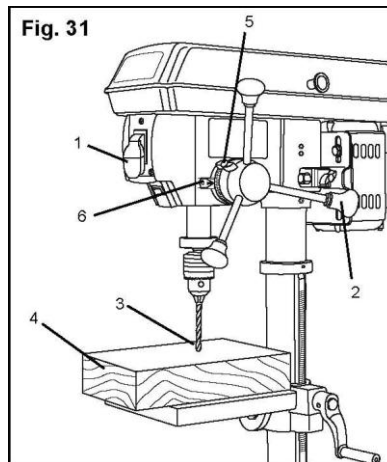

### General Drilling Guidelines



**WARNING:** To avoid injury, make sure the chuck key is removed from the chuck before starting any drilling operation.

### Drilling speeds

Important factors when determining the best drilling speed:

- Type of material
- Size of the hole to be drilled
- Type of drill bit or cutter
- Desired quality of the cut

Remember, smaller drill bits require greater speed than large drill bits. Softer materials require greater speed than harder materials.

## **Operation (continued)**

### **Drilling metal**

- Use metal-piercing twist drill bits.
- It is always necessary to lubricate the tip of the drill with oil to prevent overheating the drill bit.
- All metal workpieces should be clamped down securely. Any tilting, twisting, or shifting causes a rough drill hole, and increases the potential of drill bit breakage.
- Never hold a metal workpiece with your bare hands. The cutting edge of the drill bit may seize the workpiece and throw it, causing serious injury. The drill bit will break if the metal piece suddenly hits the column.
- If the metal is flat, clamp a piece of wood under it to prevent turning. If it cannot be laid flat on the table, then it should be blocked and clamped.

### **Drilling wood**

- Brad point bits are preferred. Metal piercing twist bits may be used on wood.
- Do not use auger bits. They turn so rapidly that they lift the workpiece off the table and whirl it around.
- Always protect the drill bit by positioning the table so the drill bit will enter the center hole when drilling through the workpiece.
- To prevent splintering, feed slowly when the bit is about to cut through to the backside of the workpiece.
- To reduce splintering and protect the point of the bit, use scrap wood as a backing or a base block under the workpiece.

### **Feeding the bit**

- Pull down on the feed handles with only enough force to allow the drill bit to cut.
- Feeding too rapidly might stall the motor, cause the belt to slip, damage the workpiece, or break the drill bit.
- Feeding too slowly will cause the drill bit to heat up and burn the workpiece.



## Maintenance



**WARNING:** For your own safety, turn the switch OFF and remove the plug from the power source before maintaining or lubricating the drill press.

Blow out or vacuum sawdust or metal chips that accumulate in and on the motor, pulley housing, table, and work surface.

Apply a light coat of paste wax to the column and table to help keep these surfaces clean and rust-free.

The ball bearings in the spindle and the V-belt pulley assembly are greased and permanently sealed. Pull the spindle down and oil the spindle sleeve moderately every three months.

Lubricate the table bracket and locking knobs if they become difficult to use.

**CAUTION:** All servicing of the drill press should be performed by a qualified service technician.

# Exploded view

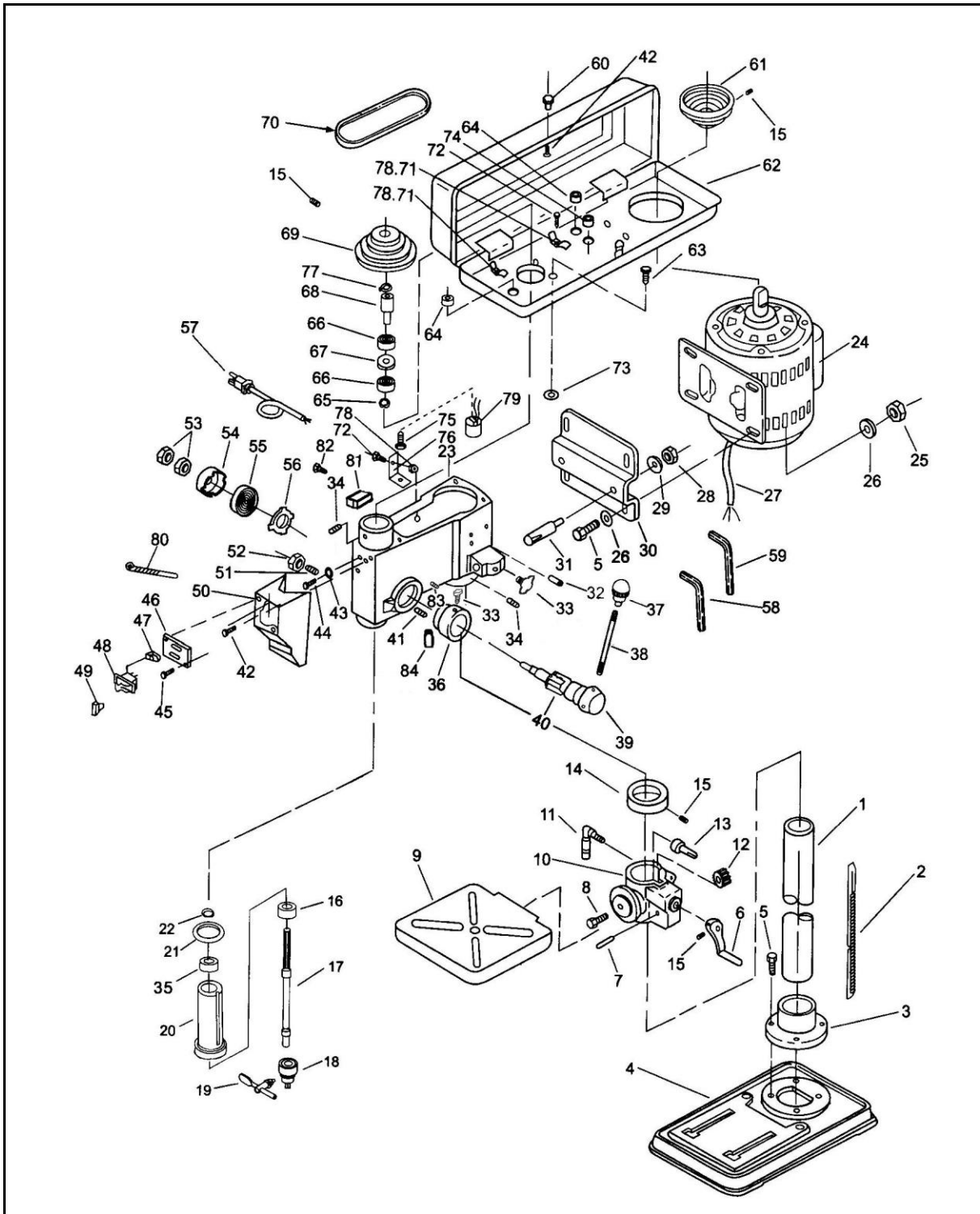

## Parts list

No.	Stock #	Description	Qty
1	90219-001	Column tube	1
2	90219-002	Rack	1
3	90219-003	Support column	1
4	90219-004	Base	8
5	90219-005	Hex head screw	1
6	90219-006	Crank handle	1
7	90219-007	Gear pin	1
8	90219-008	Hex head screw	1
9	90219-009	Table	1
10	90219-010	Table support	1
11	90219-011	Column clamp	1
12	90219-012	Gear helical	1
13	90219-013	Worm shaft	1
14	90219-014	Rack collar	1
15	90219-015	Hex socket screw	1
16	90219-016	Ball bearing	1
17	90219-017	Spindle	1
18	90219-018	Chuck	1
19	90219-019	Chuck key	1
20	90219-020	Quill tube	1
21	90219-021	Quill gasket	1
22	90219-022	Retaining ring	1
23	90219-023	Head	1
24	90219-024	Motor	1
25	90219-025	Hex nut	4
26	90219-026	Washer	8
27	90219-027	Motor cord	1
28	90219-028	Hex nut	2
29	90219-029	Lock washer	2
30	90219-030	Motor mount	1
31	90219-031	Motor support	2
32	90219-032	Roll pin	2
33	90219-033	Motor adjust knob	3
34	90219-034	Hex socket screw	2
35	90219-035	Ball bearing	1
36	90219-036	Depth stop ring	1
37	90219-037	Knob	3
38	90219-038	Rod	3
39	90219-039	Hub	1
40	90219-040	Shaft pinion	1
41	90219-041	Pin stop	1
42	90219-042	Screw	3

No.	Stock #	Description	Qty
43	90219-043	Lock washer	2
44	90219-044	Screw	2
45	90219-045	Pan cross screw	2
46	90219-046	Switch plate cover	1
47	90219-047	Rocker switch	1
48	90219-048	Lock switch	1
49	90219-049	Switch key	1
50	90219-050	Switch box	1
51	90219-051	Socket set screw	1
52	90219-052	Hex nut	1
53	90219-053	Hex nut	2
54	90219-054	Spring cap	1
55	90219-055	Spring	1
56	90219-056	Retaining spring	1
57	90219-057	Power cord	1
58	90219-058	Hex wrench	1
59	90219-059	Hex wrench	1
60	90219-060	Knob	1
61	90219-061	Pulley spindle	1
62	90219-062	Guard	1
63	90219-063	Washer screw	4
64	90219-064	Bushing rubber	2
65	90219-065	Retaining ring	1
66	90219-066	Ball bearing	2
67	90219-067	Spacer	1
68	90219-068	Pulley insert	1
69	90219-069	Pulley spindle	1
70	90219-070	V-belt	1
71	90219-071	Cord clamp	2
72	90219-072	Screw	3
73	90219-073	Foam washer	4
74	90219-074	Screw	1
75	90219-075	Screw	2
76	90219-076	Bulb socket bracket	1
77	90219-077	Retaining ring	1
78	90219-078	Hex nut	3
79	90219-079	Light	1
80	90219-080	Tie wire	3
81	90219-081	Laser battery box	1
82	90219-082	Pan cross Screw	2
83	90219-083	Hex socket screw	2
84	90219-084	Laser	2

## **Warranty**

### **PERFORMAX® (10" DRILL PRESS) WARRANTY**

#### **30-DAY MONEY BACK GUARANTEE:**

This PERFORMAX® brand power tool carries our 30-Day Money Back Guarantee. If you are not completely satisfied with your PERFORMAX® brand power tool for any reason within thirty (30) days from the date of purchase, return the tool with your original receipt to any MENARDS® retail store, and we will provide you a refund – no questions asked.

#### **2-YEAR LIMITED WARRANTY:**

This PERFORMAX® brand power tool carries a 2-Year Limited Warranty to the original purchaser. If, during normal use, this PERFORMAX® power tool breaks or fails due to a defect in material or workmanship within two (2) years from the date of original purchase, simply bring this tool with the original sales receipt back to your nearest MENARDS® retail store. At its discretion, PERFORMAX® agrees to have the tool or any defective part(s) repaired or replaced with the same or similar PERFORMAX® product or part free of charge, within the stated warranty period, when returned by the original purchaser with original sales receipt. Notwithstanding the foregoing, this limited warranty does not cover any damage that has resulted from abuse or misuse of the Merchandise. This warranty: (1) excludes expendable parts including but not limited to blades, brushes, belts, bits, light bulbs, and/or batteries; (2) shall be void if this tool is used for commercial and/or rental purposes; and (3) does not cover any losses, injuries to persons/property or costs. This warranty does give you specific legal rights and you may have other rights, which vary from state to state. Be careful, tools are dangerous if improperly used or maintained. Seller's employees are not qualified to advise you on the use of this Merchandise. Any oral representation(s) made will not be binding on seller or its employees. The rights under this limited warranty are to the original purchaser of the Merchandise and may not be transferred to any subsequent owner. This limited warranty is in lieu of all warranties, expressed or implied including warranties or merchantability and fitness for a particular purpose. Seller shall not be liable for any special, incidental, or consequential damages. The sole exclusive remedy against the seller will be for the replacement of any defects as provided herein, as long as the seller is willing or able to replace this product or is willing to refund the purchase price as provided above. For insurance purposes, seller is not allowed to demonstrate any of these power tools for you.

For questions / comments, technical assistance or repair parts –  
Please Call Toll Free at: 1-888-315-3080 (M-F 8am – 5pm CST)

**SAVE YOUR RECEIPTS. THIS WARRANTY IS VOID WITHOUT THEM.**