

INSTRUCTION MANUAL FOR



No. 499
No. 500

No. 520



CRAIN

#499 Double Case / #500 Single Case Stretcher
#520 Swivel-Lock Stretcher

CAUTION:

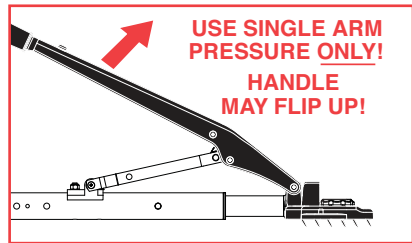
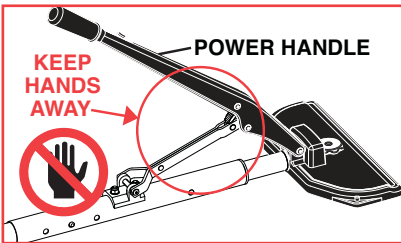

Keep hands away from area under power handle. Hand or finger may be sheared. If excessive pressure is applied to handle, it may flip up. Keep body parts away.

Congratulations on buying a Crain Junior Power Stretcher, the most technically advanced stretcher in the industry!

NOS. 499 AND 500 JUNIOR POWER STRETCHERS

WHAT'S INCLUDED:

- 1 Adjustable Locking Power Head
- 1 Auto-Lok Tube
- 3 Extension Tube Sections
- 1 Transfer Tube Section
- 1 Folding Tail Block
- 2 High-impact Plastic Carrying Cases (#499 only)
- 1 High-impact Plastic Carrying Case (#500 only)

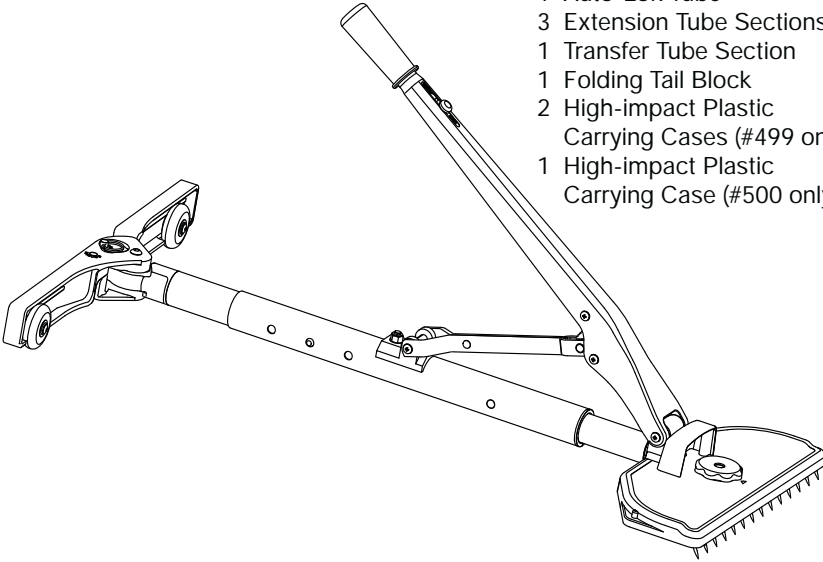

NO. 520 SWIVEL-LOCK POWER STRETCHER

WHAT'S INCLUDED:

- 1 Swivel-Lock Power Head
- 1 Auto-Lok Tube
- 3 Extension Tube Sections
- 1 Transfer Tube Section
- 1 Folding Tail Block
- 2 High-impact Plastic Carrying Cases

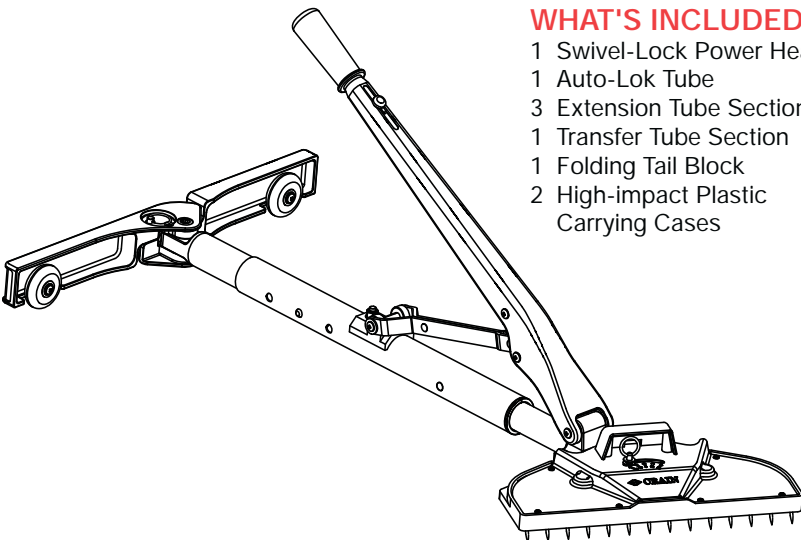

USING YOUR JUNIOR POWER STRETCHER

ASSEMBLY ON THE JOB

- A. Place the Power Head 4 inches from the starting wall at the prescribed angle for the kind of carpet you are installing. (See figure 1.) See stretch pattern diagrams on pages 5-7 for general rules, but always follow the carpet manufacturer's recommendations.
- B. Attach the Auto-Lok Tube first in line with the Power Head, and then add Extension Tube Sections until you reach the wall. The shorter Transfer Tube Section can be used in places where Extension Tubes are too long. It can also be used together with the other tubes when maximum length (23' 2") is needed. Be sure to maintain the proper angle as you extend the tubes.

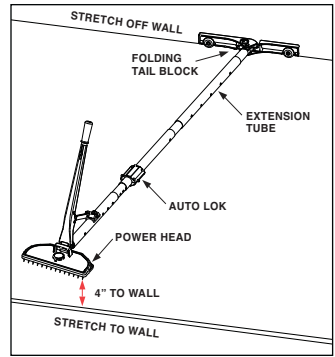

Figure 1

- C. Extra Extension Tubes can get you the extra 4' 8" you'll need on big jobs. These are available through your Crain distributor (Order No. 502).
- D. Finally, attach Folding Tail Block and place against the stretch-off wall. The wheels lift it over most existing base shoe, protecting it from damage. (See figures 12 & 13.)

ABOUT THE POWER HEAD

- A. First, adjust the pin depth, so that the pins penetrate into, but not through, the carpet's backing. The model No. 499/500 stretcher has a dial knob on top of the power head to adjust pin depth. Turn clockwise for greater pin depth penetration, or counter-clockwise for reduced penetration. (See next page for adjusting for model No. 520).
- B. Press down on the power stretcher handle to stretch carpet to the wall.

- C. You can lock the stretcher at any point by pushing the locking button forward to the position marked "LOCK". The handle also locks at the bottom of its downward movement. To release the lock, pull the button back to the position marked "UNLOCK". When lock is on, or when releasing lock, DO NOT LIFT THE POWER HANDLE. DAMAGE TO STRETCHER MAY RESULT. (See figure 2.)

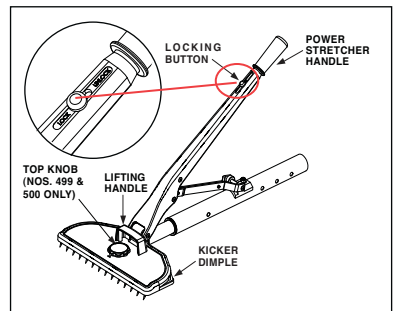

Figure 2

- D. Dimples on the head mate with knee kickers, when sideways stretching is required.

No. 520 SWIVEL-LOCK HEAD

- A. The Swivel-Lock Head has a full 60° range of free swivel. This is useful for matching patterned carpet. (See figure 3.)
- B. By depressing the built-in lock pin, you can lock the swivel in one of 5 convenient positions.

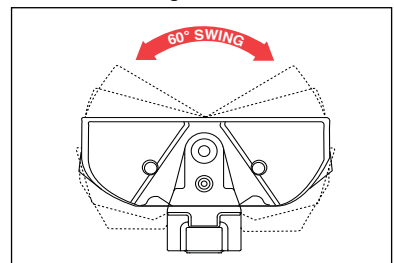

Figure 3

- C. Lock at 15° for normal angle stretching (See figure 4). Lock at 30° for extreme angles such as those often found in living room/dining rooms. (See figure 5.)

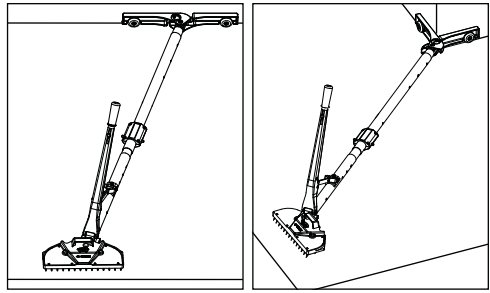

Figure 4

Figure 5

Lock in the center (0°) for use as a conventional fixed head stretcher.

- D. With the No. 520, pin depth adjustment is made using the two screws in the pin plate. (See figure 6.)

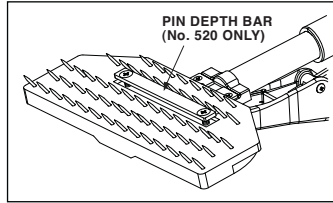

Figure 6
No. 520
Pin Depth Bar
adjusts with two
screws.

ABOUT THE AUTO-LOK TUBE

- A. The Auto-Lok Tube allows small adjustments to the length of the tubes quickly and easily. Simply push back on tubes to extend. Press in on the two buttons and pull back on the tubes to shorten. (See figure 7.)

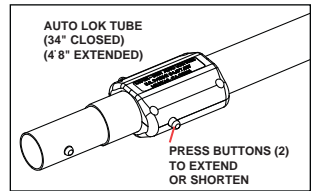

Figure 7

ABOUT THE TUBE SECTIONS

- A. Button to button, each Extension Tube Section extends a total of 4' 8", and the Transfer Tube Section extends 16", allowing the tubes to extend 23' 2" with the Auto-Lok fully extended. (See figure 8.)
- B. Always keep the tubes in a straight track whenever you apply power. Your stretcher tubes are produced from hi-yield resistant steel, but they can be bent if they are allowed to bow under extreme pressure. Keeping the tubes in a straight track will prevent this type of damage from occurring.

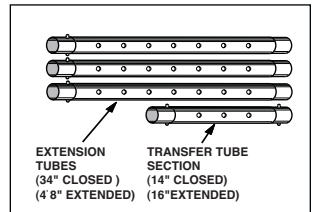

Figure 8

ABOUT THE FOLDING TAIL BLOCK

- A. For normal stretching, the tail block should stay flat against the wall, and the tube should pivot freely to permit angle stretching. Remove the lock pin, extend the legs into a flat orientation and insert the pin into the back hole marked "WALLS". (See figure 9.)

WARNING: The tail block is 20" long, and spans common 16" wall centers. Be certain at least two wall studs support the tail block, or damage to walls may result. Use a longer wood block to support the wall when necessary.

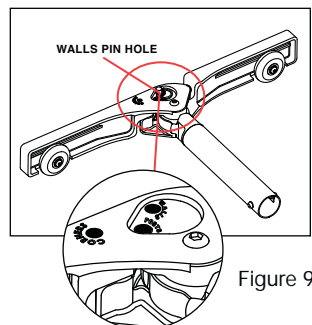

Figure 9

B. For stretching off corners (or square posts), the tail block must be folded to a 90° angle, but the tube still needs to swivel freely. Remove the lock pin, fold the legs to a 90° angle, and reinsert the lock pin into the back left hole marked "CORNERS". (See figure 10.)

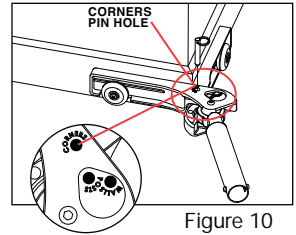

Figure 10

C. For stretching off round posts, the tail block must be folded at a 135° angle, but the tube needs to be locked and not swivel. Remove the lock pin, fold the legs to a 135° angle and align the notch in the back of the pivot. Reinsert the lock pin into the front hole marked "POSTS". (See figure 11.)

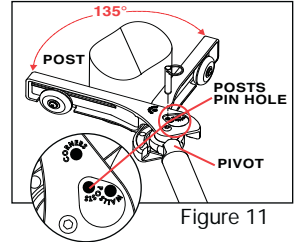

Figure 11

D. With the wheels down, the tail block clears most existing base shoe. (See figure 12.)

E. Turning the tail block over to its flat side prevents rolling and helps the tail block stay put. (See figure 13.)

F. The white non-skid surface prevents walls from being scratched or scuffed.

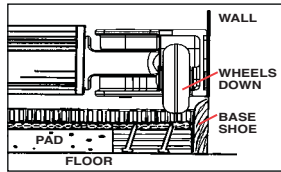

Figure 12

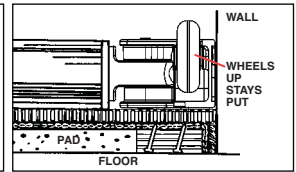

Figure 13

STRETCHING CARPET

Follow the carpet manufacturer's recommendations for the method and amount of stretch to be used. When recommendations are not available, general guidelines are provided in the stretch pattern diagrams (see pages 5-7). Tufted carpet with jute secondary back should be stretched "drum tight." Tufted carpet with synthetic secondary back should be stretched 1 to 1½% in width and length.

Some woven carpet, such as velvet, does not stretch in length, while other woven carpet, such as Axminster, has no stretch in width. Where there is no stretch, the carpet should be power stretched "snug" in these directions.

The Carpet and Rug Institute Standards Booklets #104 and #105 state that "the use of power stretchers is mandatory" on all stretch-in jobs using tackless strip.¹

MAINTENANCE AND CARE

A. Always store all the stretcher parts properly in their protective case. Store the stretcher case in a dry place.

B. Your stretcher tubes are plated to prevent rust. Frequently cleaning and lubricating them pays off with longer useful life and ease of adjustment.

C. Periodically lubricate all moving parts on the power head and Auto-Lok Tube for improved performance and longer useful life.

D. Replace all worn or broken parts as soon as possible. Your authorized Crain distributor can provide all the genuine Crain repair parts you should require.

¹ *The Carpet and Rug Institute Standard Industry Reference Guide for Installation of Residential Floor Covering Materials (CRI 104)*, and *Standard Industry Reference Guide for Installation of Commercial Floor Covering Materials (CRI 105)* (Carpet and Rug Institute: 1993), p. 17 (CRI 104), and p. 30 (CRI 105).

GREAT NEW ACCESSORIES FOR YOUR CRAIN JUNIOR POWER STRETCHER!



No. 161

No. 161 Carpet Spreader

The Carpet Spreader holds the carpet on the tack strip as you release the stretch. This helps force the carpet backing down onto the tack strip pins, for a much improved hold. The brushed stainless steel blade handles 12" of carpet.

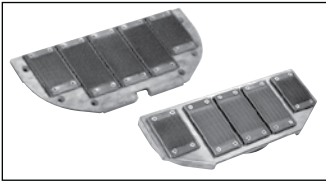

No. 500Z

No. 520Z

Cotton Grip Heads

Cotton Heads are used for stretching berbers and low-level commercial carpets. The nap grips won't snag or pull loops. The No. 500Z is for No. 499 or No. 500 Stretchers. The No. 520Z is for the Crain No. 520 Stretcher.



No. 507

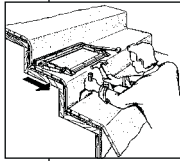

No. 507 Stairway Stretcher

Stretching stairs with a knee kicker is awkward and causes sore knees. Using the No. 507, you work with gravity, starting at the top stair. Its expanding jaws stretch the carpet, making it easy to tuck the gully below. The stretch is tighter and more uniform, and done without sore knees!

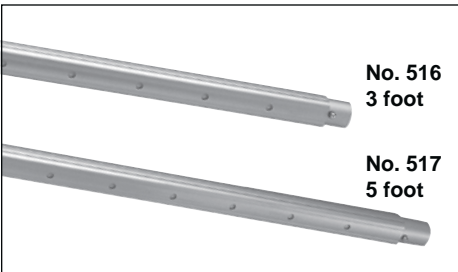

No. 516
3 foot

No. 517
5 foot

Aluminum Stretcher Poles

Aluminum stretcher poles are lighter and rustproof. The longer No. 517 five foot tube is long enough for most rooms so you can carry just one tube on the job.



No. 514

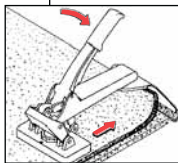

No. 514 Mini-Stretcher w/Seam Repair Attachment

Used for stretching in close quarters, restretching, or in rooms where the tail block can't be braced against an opposite wall. It pulls with the tail blade off the tack strip. Now comes with seam repair attachment which is also helpful for pattern matching. Comes with plastic carrying case.

TUFTED

Amount of stretch as per the carpet manufacturer's recommendation.
 In absence of carpet manufacturer's recommendation, use diagram below: ²

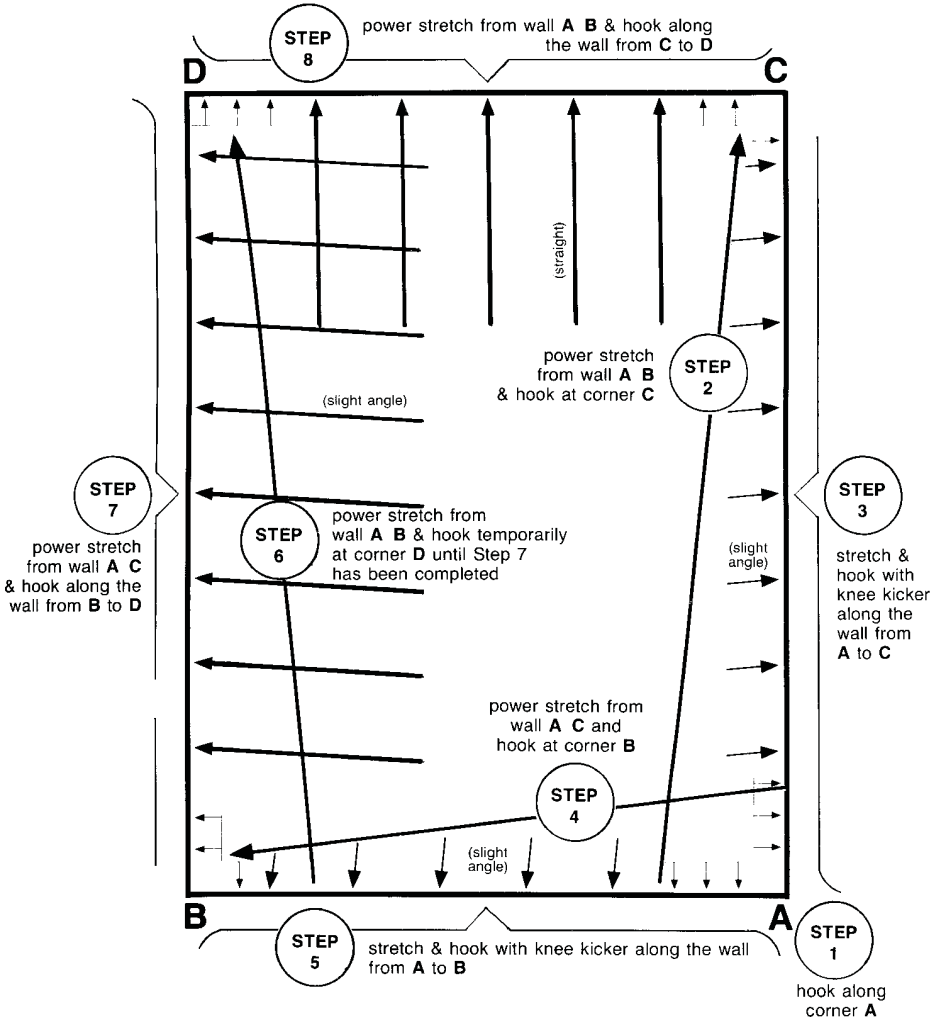

STRETCH:

	Length	Width
Jute Secondary Backing:	"drum tight"	"drum tight"
Synthetic Secondary Backing:	1% - 1½%	1% - 1½%

²The Carpet and Rug Institute Standard Industry -Reference Guide for Installation of Residential Floor Covering Materials (CRI 104) and Standard Industry Reference Guide for Installation of Commercial Floor Covering Materials (CRI 105) (Carpet and Rug Institute: 1993) p. 27 (CRI 104) and p. 51 (CRI 105).

WILTON OR VELVET

Amount of stretch as per the carpet manufacturer's recommendation. In absence of carpet manufacturer's recommendation, use diagram below: ³

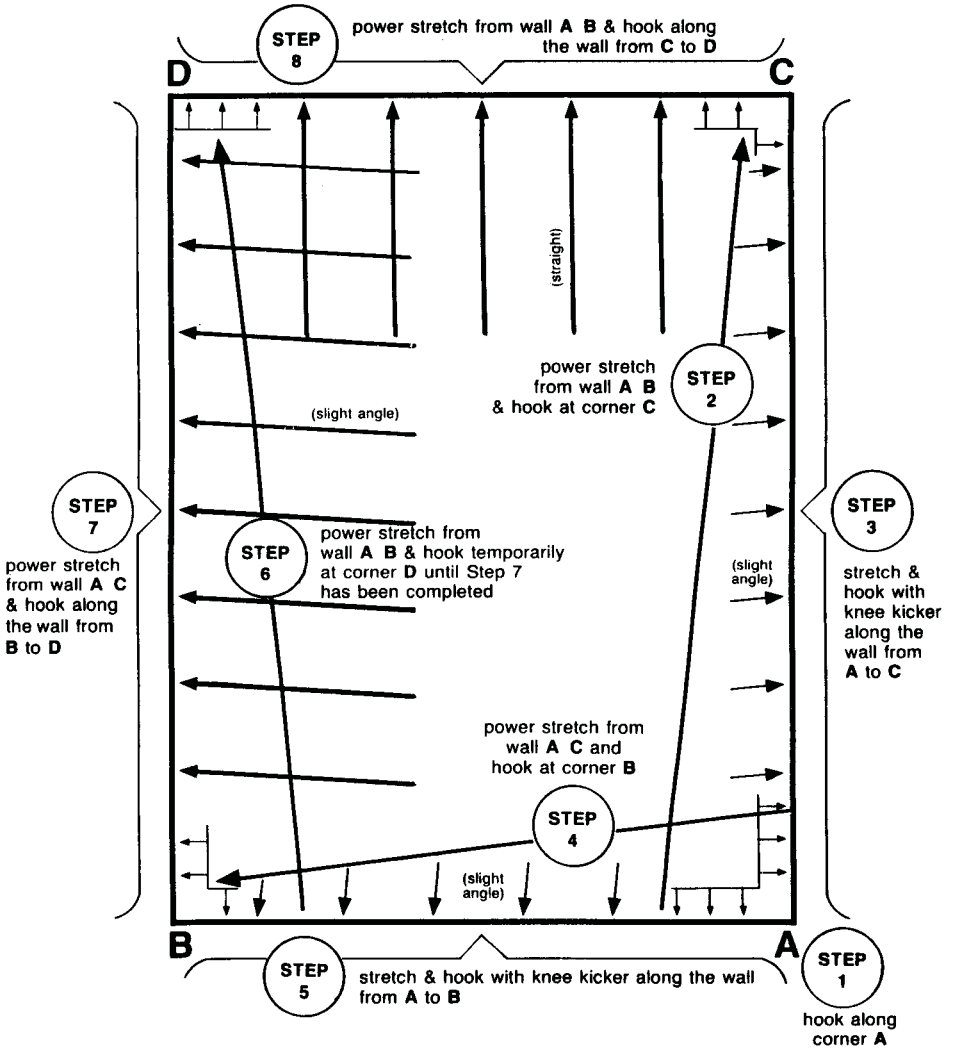

STRETCH:	Length	Width
Wilton:	equal stretch in length and width (drum tight)	equal stretch in length and width (drum tight)
Velvet:	snug	more stretch in width than length

³ The Carpet and Rug Institute Standard Industry Reference Guide for Installation of Residential Floor Covering Materials (CRI 104) and Standard Industry Reference Guide for Installation of Commercial Floor Covering Materials (CRI 105) (Carpet and Rug Institute: 1993) p. 28 (CRI 104) and p. 52 (CRI 105).

AXMINSTER

Amount of stretch as per the carpet manufacturer's recommendation.
 In absence of carpet manufacturer's recommendation, use diagram below: ⁴

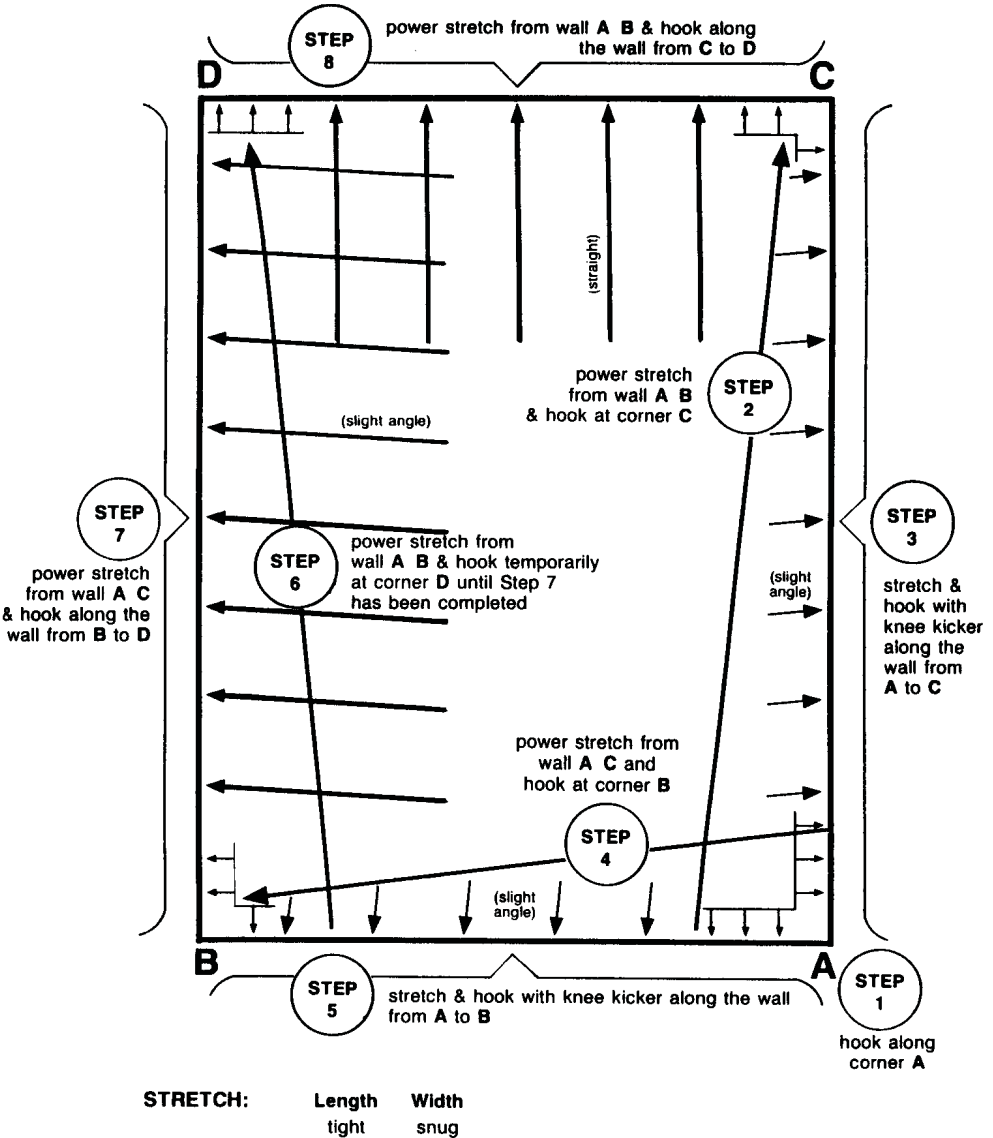

⁴ The Carpet and Rug Institute Standard Industry Reference Guide for Installation of Residential Floor Covering Materials (CRI 104) and Standard Industry Reference Guide for Installation of Commercial Floor Covering Materials (CRI 105) (Carpet and Rug Institute: 1993) p. 29 (CRI 104) and p. 53 (CRI 105).

REPLACEMENT PARTS AVAILABLE:

NO. 499 & 500 JUNIOR POWER STRETCHER

ORDER #	DESCRIPTION
1500-1	Handle
1500-2	Head, Tube & Adjusting Knob Assy.
1500-3	Thruster Tube w/Studs
1500-4	Ratchet and Thruster Assembly
1500-5	Nylon Bearing Set
1500-6	Dog
1500-7	Lock Spring
1500-8	Lock Button w/Fasteners (3)
1500-9	Dog Pin w/Fasteners (4)
1500-10	Ratchet Pin w/Fasteners (4)
1500-11	Handle Pin w/Fasteners (4)
1500-12	Saddle Pin w/Fasteners (4)
1500-13**	Saddle Fasteners Only (4)
1500-14	Lifting Handle w/Fasteners (2)
1500-15	Tail Block Right Half
1500-16	Tail Block Left Half
1500-17	Tail Block Pivot Tube
1500-18	Tail Block Lock Pin
1500-19	Tail Block Bushing
1500-20	Tail Block Cap Screw
1500-21*	Tail Block Wheel Fasteners (2)
1500-22	Brass Washer
1500-23	Folding Tail Block Complete
1500-A	Pin Plate w/Screws (7)
1500-E**	Saddle Casting & Fasteners (4)
1500-F	Depth Bar w/Screws (2)
1500-P	Spring Clip
1500-Q	2 Piece Transfer Tube
1500-S	Pin Plate Pins (10)
1500-U	DRIVING HEAD COMPLETE
1500-V*	Wheels Set (2) & Screws (4)
1375-G	Handle Grip
1499-31	Pin Plate Fasteners only (7)
1499-M2	NEW Wide Metal Latch Set (2)
1500-33	1/4-20 x 1/2" Truss Head Screws (2)
1500-34	Lock Button Fasteners Only (2)
1500-35	Handle Bushing Set (4)
1500-36	Head Bushing Only
1500-37	Pin Clip & Cap Set (4)

*To completely replace wheels (2), both 1500-21 and 1500-V are needed.

**1500-13 & 1500-E do not come with studs. Must be factory assembled on 1500-3.

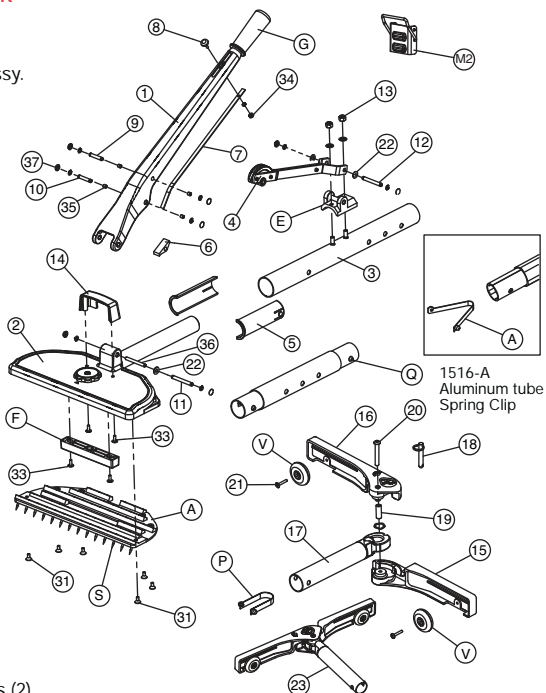

NO. 520 SWIVEL-LOCK STRETCHER

ORDER #	DESCRIPTION
1500-I	NEW Lifting Handle & Screws (2)
1520-A	Swivel Casting Plate w/Tube
1520-B	Top Cover w/Screws (6)
1520-C	Handle Support w/Screws (2)
1520-F	Lock Pin Assembly (5 pcs.)
1520-H	Bushing and Fasteners Set (3)
1520-I	Swivel Support w/Screws (4)
1520-J	Swivel Strap w/Screws (4)
1520-K	Pin Plate
1520-L	Depth Bar
1520-11	Depth Bar Fasteners Set (4)
1520-11	Top Cover Fasteners Only (6)
1520-12	Swivel Strap Fasteners Only (4)
1520-13	Swivel Support Fasteners Only (4)
1520-14	Handle Support Fasteners Only (2)
1520-Z	SWIVEL DRIVING HEAD COMPLETE

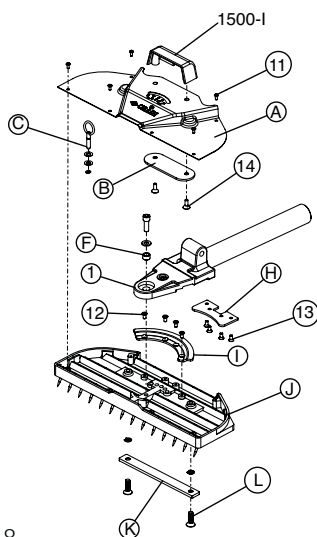

See the No. 500 parts list for unlisted No. 520 parts which are common to the No. 500.

CRAIN GUARANTEE

This Crain Stretcher is guaranteed to be free of defects in workmanship or quality of materials for a period of ONE YEAR.

Any parts of tools found defective subject to the guarantee will be replaced at no charge. Credit in full or part cannot be extended by the distributor. New tools will not be given as replacements for those pending a warranty adjustment.

All merchandise returned subject to this warranty must be accompanied with same. All merchandise returned must be F.O.B. Milpitas, California, and must be in complete assembled units. No consideration will be given to unassembled parts.

All disputes will be up to the consideration of the CRAIN CUTTER CO., INC. and their decision will be final.

Please fill out and mail this card to validate your CRAIN guarantee.

NAME _____

ADDRESS _____

CITY _____

STATE _____ ZIP _____

TOOL PURCHASED:

#499 or #500 STRETCHER

#520 SWIVEL-LOCK STRETCHER

PURCHASED FROM: _____

DATE PURCHASED: _____

PLEASE CHECK:

INDIVIDUAL FLOORING INSTALLER

WORKROOM

FLOORING DEALER

INSTALLATION CONTRACTOR

OTHER _____

PLACE
STAMP
HERE

Crain Cutter Co., Inc.
1155 Wrigley Way
Milpitas, CA 95035-5426