



# SCAFFOLDING SAFETY GUIDELINES

as Recommended by SCAFFOLDING, SHORING & FORMING INSTITUTE

It shall be the responsibility of all employers and employees to read and comply with the following common sense guidelines which are designed to promote safety in the erecting and dismantling of scaffolds. These guidelines do not purport to be all-inclusive nor to supplant or replace other additional safety and precautionary measures to cover usual or unusual conditions. Local, State or Federal statute or regulations shall supersede these guidelines if there is a conflict and it is the responsibility of each employee to comply.

## GENERAL GUIDELINES

- I. **POST THESE SCAFFOLDING SAFETY GUIDELINES** in a conspicuous place and be sure that all persons who erect, dismantle or use scaffolding are aware of them.
- II. **FOLLOW ALL STATE, LOCAL AND FEDERAL CODES, ORDINANCES AND REGULATIONS** pertaining to scaffolding because they may be more restrictive. For example, height or width requirements may vary.
- III. **SURVEY THE JOB SITE**—A survey shall be made of the job site for hazards, such as untamped earth fills, ditches, debris, high tension wires, unguarded openings, and other hazardous conditions created by other trades. These conditions shall be corrected or avoided as noted in the following sections.
- IV. **INSPECT ALL EQUIPMENT BEFORE USING**—Never use any equipment that is damaged or defective in any way.
- V. **KEEP ALL EQUIPMENT IN GOOD REPAIR**—Avoid using corroded equipment—the strength of corroded equipment is not known.
- VI. **INSPECT ERECTED SCAFFOLDS DAILY**—or at the beginning of every shift to be sure that they are maintained in safe condition.
- VII. **NEVER USE EQUIPMENT FOR PURPOSES OR IN WAYS FOR WHICH IT WAS NOT INTENDED.**
- VIII. **REPORT ANY UNSAFE CONDITION. NEVER TAKE CHANCES**—Do not work on scaffolds if your physical condition is such that you feel dizzy or unsteady in any way.
- IX. **WORKING UNDER THE INFLUENCE OF ALCOHOL OR ILLEGAL DRUGS IS STRICTLY PROHIBITED.**
- X. **CONSULT YOUR SCAFFOLDING SUPPLIER**—Consult manuals and instructions provided by the supplier; scaffolding is his business.

## GUIDELINES FOR ERECTION AND USE OF SCAFFOLDS

- A. PROVIDE ADEQUATE SKILLS for scaffold posts and use base plates.
- B. USE ADJUSTING SCREWS or other approved conditions.
- C. PLUMB AND LEVEL ALL SCAFFOLDS as the erection proceeds. Do not force braces to fit—level the scaffold until proper fit can be made easily.
- D. BRACING. Each frame or panel shall be braced by horizontal bracing, cross bracing, diagonal bracing or any combination thereof for securing vertical members together laterally. All brace connections shall be made secure, in accordance with manufacturers' recommendations.
- E. DO NOT CLIMB CROSS BRACES. Use only an access (climbing) ladder, access steps, frame designed to be climbed or equivalent safe access to scaffold.
- F. THE RUNNING SCAFFOLD TO WALL or structure when the height exceeds four (4) times the minimum scaffold base dimension. The first vertical and longitudinal tie shall be placed at this point. Vertical ties shall be repeated at intervals not greater than 26 feet. Longitudinal ties shall be placed at each end and at intervals not greater than 30 feet. Ties must prevent the scaffold from tipping into or away from the wall or structure.
- G. WHEN SCAFFOLDS ARE TO BE PARTIALLY OR FULLY ENCLOSED, specific precautions must be taken to assure frequency and adequacy of ties attaching the scaffolding to the building due to increased load conditions resulting from effects of wind and weather. The scaffolding components to which the ties are attached must also be checked for additional loads.
- H. WHEN FREE STANDING SCAFFOLD TOWERS exceed four times their minimum base dimension vertically, they must be restrained from tipping.
  - I. DO NOT ERECT SCAFFOLDS NEAR ELECTRICAL POWER LINES UNLESS PROPER PRECAUTIONS ARE TAKEN. Consult the power service company for advice.
  - J. DO NOT USE ladders or makeshift devices on top of scaffolds to increase the height.
  - K. DO NOT EXCEED MANUFACTURERS' RECOMMENDED LOAD RATING.
  - L. EQUIP AND MAINTAIN ALL PLATFORMS with proper guardrails, midrails, and toeboards along all open sides and ends of scaffold platforms.
  - M. ALL BRACKETS shall be sealed correctly with side brackets parallel to the frames and end brackets at 90 degrees to the frames. Brackets shall not be bent or twisted from normal position. Brackets (except mobile brackets designed to carry materials) are to be used as work platforms only and shall not be used for storage of material or equipment. When brackets are used, the scaffold shall be tied to the structure or otherwise restrained to prevent tipping.
  - N. ALL SCAFFOLDING ACCESSORIES shall be used and installed in accordance with the manufacturers' recommended procedure. Accessories shall not be altered in the field. Scaffolds, frames and their components of various manufacturers shall not be intermixed.
  - O. FOR PLANKING, THE FOLLOWING GUIDELINES APPLY:
    1. Use only lumber that is properly inspected and graded as scaffold plank.
    2. Planking shall have at least 12 inches of overlap and extend 6 inches beyond center of support, or be cleated at both ends to prevent sliding off supports.
    3. Fabricated scaffold planks and platforms, unless created or restrained by hooks, shall extend over their end supports not less than 6 inches nor more than 12 inches.
- P. FOR ROLLING SCAFFOLDS THE FOLLOWING ADDITIONAL GUIDELINES APPLY.
  1. CASTERS WITH PLAIN STEMS shall be attached to the panel or adjustment screw by pins or other suitable means.
  2. DO NOT EXTEND ADJUSTING SCREWS ON ROLLING SCAFFOLDS MORE THAN 12 INCHES.
  3. WHEELS OR CASTERS shall be provided with a locking device and kept locked during erection and dismantling or any time scaffolds are not being moved.
  4. SECURE OR REMOVE ALL MATERIAL AND EQUIPMENT from platform before moving scaffold.
  5. USE HORIZONTAL DIAGONAL BRACING near the bottom and at 20 foot intervals measured from the rolling surface.
  6. DO NOT USE brackets or other platform extensions without consideration of overturning effect.
  7. THE HEIGHT OF A ROLLING SCAFFOLD excluding its uppermost guardrails, must not exceed four times its smallest base dimension unless it is stabilized by an engineered counterweight system or some other equivalent means.
  8. CLEAR OR SECURE ALL PLANKS.
  9. DO NOT ATTEMPT TO MOVE A ROLLING SCAFFOLD WITHOUT SUFFICIENT HELP—watch out for holes in floor and overhead obstructions—stabilize against tipping.
  10. DO NOT RIDE ROLLING SCAFFOLDS.
  11. JOINTS shall be restrained from separation.
- Q. FOR "PUTLOGS" AND "TRUSSES" the following additional guidelines apply.
  1. DO NOT CANTILEVER OR EXTEND PUTLOGS/TRUSSES as side brackets without thorough consideration for loads to be applied.
  2. PUTLOGS/TRUSSES SHOULD BE EXTENDED AT LEAST 6 inches beyond point of support.
  3. PLACE RECOMMENDED BRACING BETWEEN PUTLOGS/TRUSSES when the span of putlog/truss is more than 12 feet.
- R. WHEN DISMANTLING SCAFFOLDING THE FOLLOWING ADDITIONAL GUIDELINES APPLY:
  1. CHECK TO SEE IF SCAFFOLDING HAS BEEN STRUCTURALLY ALTERED in any way which would make it unsafe, and if so, reconstruct where necessary before commencing with dismantling procedures.
  2. VISUALLY INSPECT PLANK prior to dismantling to be sure that they are safe to work on.
  3. COMPONENTS SHOULD BE LOWERED as soon as dismantled in safe manner so as to protect personnel below.
  4. DO NOT ACCUMULATE EXCESS COMPONENTS OR EQUIPMENT on the level being dismantled.
  5. DISMANTLED EQUIPMENT should be stockpiled in an orderly manner.
- S. FOLLOW ERECTION PROCEDURES AND USE MANUALS.

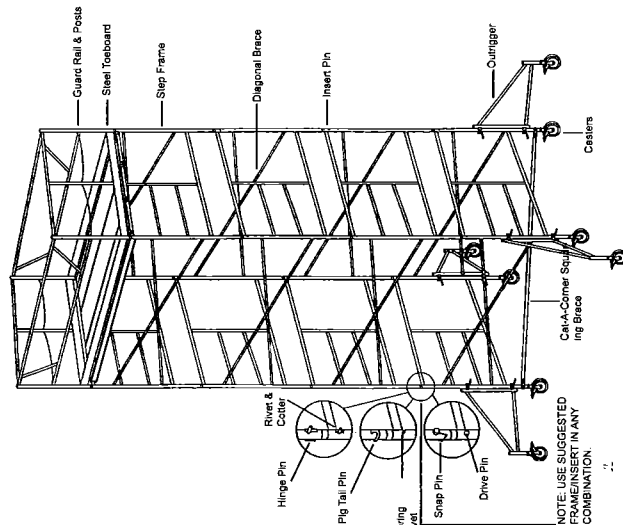
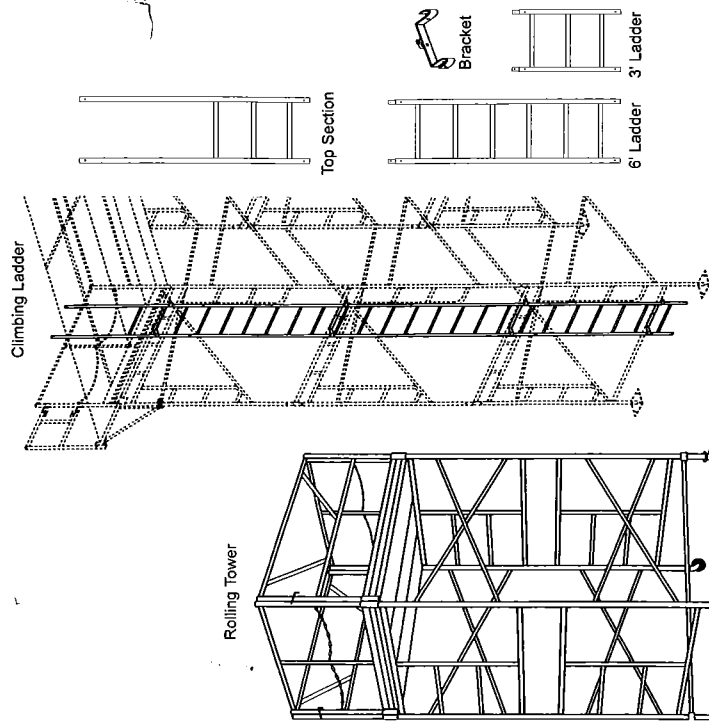
\* EXCEPTIONS: Three times in California, Ohio, Oregon, Montana, Maine.

These safety guidelines set forth common sense procedures for safely erecting and dismantling scaffolding equipment. However, equipment and scaffolding systems differ, and accordingly, reference must always be made to the instructions and procedures of the supplier or the equipment. Since field conditions vary and are beyond the control of the Institute, safe and proper use of scaffolding is the responsibility of the user and not the Institute.

Reprinting of this publication does not imply approval of product by the Institute or indicate membership in the Institute. Permission to reproduce in entirety can be obtained from Scaffolding, Shoring & Forming Institute, 1230 Keith Bldg., Cleveland, Ohio 44115

Printed in the U.S.A.

Page 2 of 2



ALL PHOTOS AND DRAWINGS ARE FOR ILLUSTRATION ONLY. FOLLOW ALL APPLICABLE ANSI AND OSHA CODES AND REGULATIONS FOR USE OF THIS EQUIPMENT. DO NOT USE IN AREA WHERE USER CAN COME IN CONTACT WITH LIVE POWER.

# RECOMMENDED SCAFFOLDING ERECTION PROCEDURE

## INTRODUCTION

*This guide has been prepared by the Scaffolding, Shoring & Forming Institute to assist contractors, architects, engineers, dealers, erectors, and users, etc., for the proper use of scaffolding equipment. Scaffolding Safety Rules published by the Institute should be used in conjunction with this publication, as well as the instructions for the use of scaffolding provided by the manufacturer. Safety precautions and requirements prescribed by local, state, and federal agencies, including OSHA, must be followed at all times and persons working with scaffolding systems should be equipped with requisite safety devices.*

## NOMENCLATURE

1. **Accessories**—Those items other than frames and braces used to facilitate the construction of scaffolding towers and structures.
2. **Adjustment Screw**—Device composed of a threaded screw and an adjusting handle used for the vertical adjustment of the scaffolding.
3. **Base Plate**—A device used to distribute the leg load.
4. **Climbing Ladders**—A separate ladder attached to the scaffolding structure or built into the scaffold frame.
5. **Casters**—Wheels of a suitable dimension and unit designed to attach to the base of a tower and containing a brake to prevent the wheels from rotating.
6. **Coupling Pin**—Device used to align and connect lifts or tiers together vertically.
7. **Cross-bracing**—System of members connecting frames or panels of scaffolding to make a tower structure.
8. **Extension Device**—Any device used to obtain vertical adjustment of scaffolding other than an adjustment screw.
9. **Factor of Safety**—the ratio of ultimate load to the allowable load.
10. **Frame or Panel\***—the principal prefabricated, welded structural unit.
11. **Guardrail**—A rail secured to uprights and erected along the exposed sides and ends of platforms.
12. **Horizontal Diagonal Bracing**—Diagonal braces running horizontally between frames of scaffolding.
13. **Lifts or Tiers\***—The number of frames stacked one above each other in a direction.
14. **Locking Device**—A device used to secure the cross brace to the panel.
15. **Putlog or Truss**—A separate horizontal load carrying member.
16. **Rolling Towers**—A composite structure of frames, braces, platforms, guardrails, and accessories supported by casters.
17. **Safe Leg Load**—That load which can safely be directly imposed on the frame leg.
18. **Safe Scaffold Frame Horizontal Member Load**—That load which can safely be directly imposed on a horizontal member.
19. **Scaffolding Layout**—An engineered drawing prepared prior to erection showing arrangement of equipment for proper scaffolding use.

20. **Side Bracket**—A cantilevered arm unit, supported by the scaffolding frame.
21. **Sill or Mud Sill\***—A footing, usually wood, which distributes the vertical leg loads to the ground.
22. **Ties**—A tension compression member used to securely attach scaffold to a structure.
23. **Toeboard**—A barrier secured along the sides and ends of a platform, to guard against the falling of material.
24. **Towers**—A composite structure of frames, braces, and accessories.
25. **Ultimate Load**—The maximum load which may be placed on the scaffolding causing failure by buckling of column members or yielding of some component.

\* These terms can be used synonymously.

## INSPECTION OF SCAFFOLDING EQUIPMENT PRIOR TO ERECTION

The three main areas of inspection are for corrosion, straightness of members and welds. This applies to all components of a scaffolding system.

1. **CORROSION**—Heavily rusted or eroded scaffolding equipment is a telltale sign of abuse or neglect.
2. **STRAIGHTNESS OF MEMBERS**—Mishandling, trucking and storing may cause damage to scaffolding equipment. All scaffolding components should be straight and free from bends, kinks or dents.
3. **WELDS**—Equipment should be checked before use for damaged welds and any piece of equipment showing damaged welds or rewelding beyond the original factory weld should not be used. The factory weld reference pertains to location and quality of rewelds. While CORROSION, STRAIGHTNESS, and WELDS are of primary concern other component parts should be checked.
4. Locking devices on frames and braces shall be in good working order, and if not, must be repaired or replaced prior to use.
5. Coupling pins must effectively align the frame or panel legs.
6. Pivoted cross braces must have the center pivot securely in place.
7. Caster Brakes shall be in good working order and if not must be repaired or replaced prior to use.

## SAFE BEARING LOADS FOR SOILS

Considering that the allowable loads (bearing) on various soils and rock range from less than 1,000 p.s.f. to more than 50,000 p.s.f. care should be exercised in determining the capacity of the soil for every scaffolding job, realizing that weather conditions can turn an otherwise suitable ground condition into a hazardous situation. As an example, dry clay with an allowable bearing capacity of 8,000 p.s.f. could become very plastic after a rainfall and drop to less than 2,000 p.s.f.

Care should also be taken not to excessively disturb the soil. If fill is required in areas where scaffolding is used, a qualified engineer should be consulted as to materials and compaction.

### **FOUNDATIONS**

The purpose of a good foundation or mud sill is to distribute the scaffolding load over a suitable ground area. The size of the footing or sill is determined by the total load carried over a particular ground area, and by the nature of the soil supporting these sills.

The total load should be computed and the sills designed accordingly.

When scaffolding from earth or fill, the areas should be leveled and the sills spaced in a pattern assuring adequate stability for all scaffolding legs.

### **ERECTION OF FRAMES**

The work of erecting the scaffolding should be under the supervision of a person with proper experience and aptitude for securing a safe installation and who is familiar with all Local, State and Federal Regulations concerning scaffolding, as well as the SSFI Scaffolding Safety Rules.

It shall be the responsibility of the person supervising the erection of the scaffold to see that all components and locking devices are in working order, and no damaged or deteriorated equipment is used in the setup. Should any scaffolding become damaged after the equipment has been erected, workmen shall not be allowed on same until the damaged items have been repaired or replaced.

Advanced planning will help the erection of scaffolding to progress smoothly. The equipment should be unloaded as close to the area of use as possible and should be arranged in the order it is to be used. Adjustment screws should be set to their approximate final adjustment before setting up the scaffolding. At this time, a person should check to see that all panels which require coupling pins have them. Consult safety rules as recommended by the Institute.

After erecting the first tier of scaffold frames, plumb and level (using instruments) all frames so that no matter how high the final scaffolding setup, the additional frames will also be in correct alignment.

As erection proceeds, securely tie all scaffolding to the structure at the ends and at least every 30' horizontally, and at height intervals not to exceed\* 4 times the minimum base dimension. Free standing scaffold towers must be restrained from tipping by guying or other means. Scaffold frames must be fastened together at coupling pins where there is a possibility of uplift.

When scaffolds are to be partially or fully enclosed, specific precautions must be taken to assure frequency adequacy of ties attaching the scaffolding to the building due to increased load conditions resulting from effects of wind and weather. The scaffolding components to which the ties are attached must also be checked for additional loads.

When erecting additional lifts, always work from planking placed within the scaffold structure. Move planking as erection progresses.

### **PLANKING AND ACCESSORIES**

Use only lumber that is properly inspected and graded for use as scaffold plank.

Planking shall have at least 12" of overlap and extend 6" beyond center of support or be cleated at both ends to prevent sliding off support. Do not allow unsupported ends of plank to extend beyond supports. Secure plank to scaffolding when necessary.

All scaffold accessories shall be used and installed in accordance with the manufacturer's recommended procedures. Accessories shall not be altered in the field.

When installing hanger or clamp supported putlogs (trusses), care should be taken to see that they extend at least 6" beyond the point of support. Also, make sure that the proper bracing is placed between putlogs (trusses). When the span between supporting members is more than 12' additional bracing between the putlogs (trusses) and the supporting member may be required. Do not cantilever or extend putlogs (trusses) as side brackets without thorough consideration for loads to be applied or transmitted to the scaffold. When clamping putlogs, clamp capacity may control rather than putlog capacity. Consult scaffold manufacturer.

All brackets should be seated correctly with side brackets parallel to the frames and the end brackets at 90 degrees to the frame. Brackets shall not be bent or twisted from normal position.

Equip all planked or staged areas with proper guard rails and add toeboards when required.

### **FINAL AND DAILY INSPECTION OF ERECTED SCAFFOLDING**

The following is a list of check points to be covered when making a final and daily inspection of scaffolding prior to use. All points should be carefully checked to insure a safe and accident-free job and be periodically rechecked.

1. Check to see that there is proper support under every leg of every frame on the job. Check also for possible washout due to rain.
2. Check to make certain that all base plates and adjustment screws are in firm contact with their supports. All adjustment nuts should be snug against the legs of the frame.
3. Frames should be checked for plumbness in both directions.
4. If there is a gap between the lower end of one frame and the upper end of another frame it indicates that one adjustment screw must be adjusted to bring the frames in contact. If this does not help it indicates the frame is out of square and should be replaced.
5. Each leg of each frame should be cross braced to the corresponding leg of the next frame.
6. While checking the cross braces also check the locking devices to assure that they are all in their closed position or that they are all tight.
7. Check to be certain that all planking and accessories are properly installed.
8. Check to make certain all ties are secured between the structure and the scaffolding.

9. Check to be certain all guard rails are in place.
10. If scaffolding is enclosed, check to see that additional precautions have been taken as noted in Section of Erection. Recheck periodically ties, clamps, etc., for movement.
11. Insure that safe access to work platform(s) is provided.

### **DISMANTLING OF SCAFFOLDING**

The work of dismantling scaffolding should be under the supervision of an individual with proper experience and aptitude. The following should be observed while dismantling.

1. Check to see if scaffolding has been structurally altered in any way which would make it unsafe, and if so reconstruct where necessary before commencing with the dismantling procedures.
2. Dismantle scaffold from the top down. Begin by removing all accessories from that lift being dismantled at the time.
3. Always work from a minimum of two plank placed on the tier of frames below those being removed. Move the planking down as dismantling progresses.
4. Do not remove ties until dismantling has reached the tier to which they are attached.
5. Always stay within the inside of the scaffold. Do not climb on the outside for any reason when dismantling. Do not climb on ties, braces or unbraced frames.
6. Only remove fastening devices from bottom of frames being removed.
7. Lower scaffolding components in a safe manner as they are dismantled. Avoid dropping or throwing the components as this could result in damage to the equipment, or injury to personnel below.

### **ERECTION OF ROLLING TOWERS**

When erecting rolling scaffolding towers, the following additional items apply. These items are in addition to the application portions of the preceding section.

1. Caster should be of adequate load capacity and size in relation to the height of the tower, the surface over which the tower is to be used and in accordance with all government, state, and local codes, ordinances, and regulations.  
Casters with plain stems shall be attached to the panel or adjustment screw by pins or other suitable means.
2. Do not extend adjusting screws on rolling towers more than 12".
3. The platform height shall not exceed\* four (4) times the smallest base dimension unless guyed or otherwise stabilized.
4. Horizontal diagonal braces should be used near the bottom, top and at 20' intervals measured from the rolling surface.
5. When side brackets are used, consideration should be given to the overturning effect these brackets will have upon the stability of the tower.
6. Cross brace every lift-both sides.
7. Install guardrails.
8. Plank according to Plank and Accessories Section of Erection Procedure.

\* EXCEPTIONS: Three times in California, Ohio, Oregon, Montana, Maine; 3-1/2 times in Washington.

### **FINAL INSPECTION OF ROLLING TOWERS**

The following additional points should be checked when making a final inspection of rolling scaffold towers prior to their use. These points are in addition to the applicable items covered under the preceding section entitled, "Final Inspection of Erected Scaffolding."

1. Check to see that the platform height does not exceed\* four (4) times the smallest base dimension unless the tower is properly guyed or otherwise stabilized.
2. Check to see that, if adjusting screws have been used, they are not extended more than 12".
3. Check to make sure the caster brakes are in good working condition and are applied when tower is not being moved.
4. Inspect to make sure horizontal diagonal bracing has been placed near the bottom, top, and at 20' intervals measured from the rolling surface. A hook on manufactured platform properly attached to the top frame may be equivalent to the top horizontal diagonal brace.
5. Cross bracing has been installed on both sides of every lift.
6. Check the area in which the tower is to be used to insure there are no obstructions either in, on, or above the floor which will interfere with the proper and safe use of the rolling tower.
7. Check for guardrails.
8. Check to see that all planks and fabricated platforms are properly installed.
9. Insure that safe access to work platform(s) is provided.

REFER TO SCAFFOLDING, SHORING & FORMING INSTITUTE SCAFFOLDING SAFETY RULES BEFORE USING SCAFFOLDING.

The procedures outlined in this Guide describe conventional procedures for erecting and dismantling scaffolding systems. However, equipment and systems differ and, accordingly, reference must always be made to the instructions and procedures of the manufacturer or supplier of the equipment. Since field conditions vary and are beyond the control of the Institute and its members, safe and proper use of this equipment is the responsibility of the user and not the Institute or its members.

### **SCAFFOLDING AND SHORING INSTITUTE**

1230 KEITH BUILDING  
CLEVELAND, OHIO 44115

# **BIL-JAX**<sup>®</sup>

125 TAYLOR PARKWAY  
ARCHBOLD, OHIO 43502

Form No. SSI-83-80-68  
LL-204-03

# SCAFFOLDING SAFETY GUIDELINES

## AS RECOMMENDED BY SCAFFOLDING, SHORING & FORMING INSTITUTE

It shall be the responsibility of all employers and employees to read and comply with the following common sense guidelines which are designed to promote safety in the erecting and dismantling of scaffolds. These guidelines do not purport to be all-inclusive nor to supplant or replace other additional safety and precautionary measures to cover usual or unusual conditions. Local, State or Federal statute or regulations shall supersede these guidelines if there is a conflict and it is the responsibility of each employee to comply.

### GENERAL GUIDELINES

- I. **POST THESE SCAFFOLDING SAFETY GUIDELINES** in a conspicuous place and be sure that all persons who erect, dismantle or use scaffolding are aware of them.
- II. **FOLLOW ALL STATE, LOCAL AND FEDERAL CODES, ORDINANCES AND REGULATIONS** pertaining to scaffolding because they may be more restrictive. For example, height or width requirements may vary.
- III. **SURVEY THE JOB SITE**—A survey shall be made of the job site for hazards, such as untamped earth fills, ditches, debris, high tension wires, unguarded openings, and other hazardous conditions created by other trades. These conditions shall be corrected or avoided as noted in the following sections.
- IV. **INSPECT ALL EQUIPMENT BEFORE USING**—Never use any equipment that is damaged or defective in any way.
- V. **KEEP ALL EQUIPMENT IN GOOD REPAIR**—Avoid using corroded equipment—the strength of corroded equipment is not known.
- VI. **INSPECT ERECTED SCAFFOLDS DAILY**—or at the beginning of every shift to be sure that they are maintained in safe condition.
- VII. **NEVER USE EQUIPMENT FOR PURPOSES OR IN WAYS FOR WHICH IT WAS NOT INTENDED.**
- VIII. **REPORT ANY UNSAFE CONDITION. NEVER TAKE CHANCES**—Do not work on scaffolds if your physical condition is such that you feel dizzy or unsteady in any way.
- IX. **WORKING UNDER THE INFLUENCE OF ALCOHOL OR ILLEGAL DRUGS IS STRICTLY PROHIBITED.**
- X. **CONSULT YOUR SCAFFOLDING SUPPLIER—NEVER TAKE CHANCES**—Consult manuals and instructions provided by the supplier; scaffolding is his business.

### GUIDELINES FOR ERECTION AND USE OF SCAFFOLDS

- A. **PROVIDE ADEQUATE SILLS** for scaffold posts and use base plates.
- B. **USE ADJUSTING SCREWS** for other approved conditions.
- C. **PLUMB AND LEVEL ALL SCAFFOLDS** as the erection proceeds. Do not force braces to fit—level the scaffold until proper fit can be made easily.
- D. **BRACING.** Each frame or panel shall be braced by horizontal bracing, cross bracing, diagonal bracing or any combination thereof for securing vertical members together laterally. All brace connections shall be made secure, in accordance with manufacturers' recommendations.
- E. **DO NOT CLIMB CROSS BRACES.** Use only an access (climbing) ladder, access steps, frame designed to be climbed or equivalent safe access to scaffold.
- F. **TIE RUNNING SCAFFOLD TO WALL** or structure when the height exceeds\* four (4) times the minimum scaffold base dimension. The first vertical and longitudinal tie shall be placed at this point. Vertical ties shall be repeated at intervals not greater than 26 feet. Longitudinal ties shall be placed at each end and at intervals not greater than 30 feet. Ties must prevent the scaffold from tipping into or away from the wall or structure.
- G. **WHEN SCAFFOLDS ARE TO BE PARTIALLY OR FULLY ENCLOSED,** specific precautions must be taken to assure frequency and adequacy of ties attaching the scaffolding to the building due to increased load conditions resulting from effects of wind and weather. The scaffolding components to which the ties are attached must also be checked for additional loads.
- H. **WHEN FREE STANDING SCAFFOLD TOWERS** exceed\* four times their minimum base dimension vertically, they must be restrained from tipping.
- I. **DO NOT ERECT SCAFFOLDS NEAR ELECTRICAL POWER LINES UNLESS PROPER PRECAUTIONS ARE TAKEN.** Consult the power service company for advice.
- J. **DO NOT USE ladders or makeshift devices** on top of scaffolds to increase the height.
- K. **DO NOT EXCEED MANUFACTURERS' RECOMMENDED LOAD RATING.**
- L. **EQUIP AND MAINTAIN ALL PLATFORMS** with proper guardrails, mid-rails, and toeboards along all open sides and ends of scaffold platforms.
- M. **ALL BRACKETS** shall be seated correctly with side brackets parallel to the frames and end brackets at 90 degrees to the frames. Brackets shall not be bent or twisted from normal position. Brackets (except mobile brackets designed to carry materials) are to be used as work platforms only and shall not be used for storage of material or equipment. When brackets are used, the scaffold shall be tied to the structure or otherwise restrained to prevent tipping.
- N. **ALL SCAFFOLDING ACCESSORIES** shall be used and installed in accordance with the manufacturers' recommended procedure. Accessories shall not be altered in the field. Scaffolds, frames and their components of various manufacturers shall not be intermixed.
- O. **FOR PLANKING, THE FOLLOWING GUIDELINES APPLY:**
  1. Use only lumber that is properly inspected and graded as scaffold plank.
  2. Planking shall have at least 12 inches of overlap and extend 6 inches beyond center of support, or, be cleated at both ends to prevent sliding off supports.
  3. Fabricated scaffold planks and platforms, unless created or restrained by hooks, shall extend over their end supports not less than 6 inches nor more than 12 inches.
  4. Secure plank to scaffold when necessary.
- P. **FOR ROLLING SCAFFOLDS THE FOLLOWING ADDITIONAL GUIDELINES APPLY.**
  1. **CASTERS WITH PLAIN STEMS** shall be attached to the panel or adjustment screw by pins or other suitable means.
  2. **DO NOT EXTEND ADJUSTING SCREWS ON ROLLING SCAFFOLDS MORE THAN 12 INCHES.**
  3. **WHEELS OR CASTERS** shall be provided with a locking device and kept locked during erection and dismantling or any time scaffolds are not being moved.
  4. **SECURE OR REMOVE ALL MATERIAL AND EQUIPMENT** from platform before moving scaffold.
  5. **USE HORIZONTAL DIAGONAL BRACING** near the bottom and at 20 foot intervals measured from the rolling surface.
  6. **DO NOT USE brackets or other platform extensions** without consideration of overturning effect.
  7. **THE HEIGHT OF A ROLLING SCAFFOLD** excluding its uppermost guardrails, must not exceed\* four times its smallest base dimension unless it is stabilized by an engineered counterweight system or some other equivalent means.
  8. **CLEAT OR SECURE ALL PLANKS.**
  9. **DO NOT ATTEMPT TO MOVE A ROLLING SCAFFOLD WITHOUT SUFFICIENT HELP**—watch out for holes in floor and overhead obstructions—stabilize against tipping.
  10. **DO NOT RIDE ROLLING SCAFFOLDS.**
  11. **JOINTS** shall be restrained from separation.
- Q. **FOR "PUTLOGS" AND "TRUSSES"** the following additional guidelines apply.
  1. **DO NOT CANTILEVER OR EXTEND PUTLOGS/TRUSSES** as side brackets without thorough consideration for loads to be applied.
  2. **PUTLOGS/TRUSSES SHOULD BE EXTENDED AT LEAST 6 inches** beyond point of support.
  3. **PLACE RECOMMENDED BRACING BETWEEN PUTLOGS/TRUSSES** when the span of putlog/truss is more than 12 feet.
- R. **WHEN DISMANTLING SCAFFOLDING THE FOLLOWING ADDITIONAL GUIDELINES APPLY:**
  1. **CHECK TO SEE IF SCAFFOLDING HAS BEEN STRUCTURALLY ALTERED** in any way which would make it unsafe, and if so, reconstruct where necessary before commencing with dismantling procedures.
  2. **VISUALLY INSPECT PLANK** prior to dismantling to be sure that they are safe to work on.
  3. **COMPONENTS SHOULD BE LOWERED** as soon as dismantled in safe manner so as to protect personnel below.
  4. **DO NOT ACCUMULATE EXCESS COMPONENTS OR EQUIPMENT** on the level being dismantled.
  5. **DISMANTLED EQUIPMENT** should be stockpiled in an orderly manner.
- S. **FOLLOW ERECTION PROCEDURES AND USE MANUALS.**

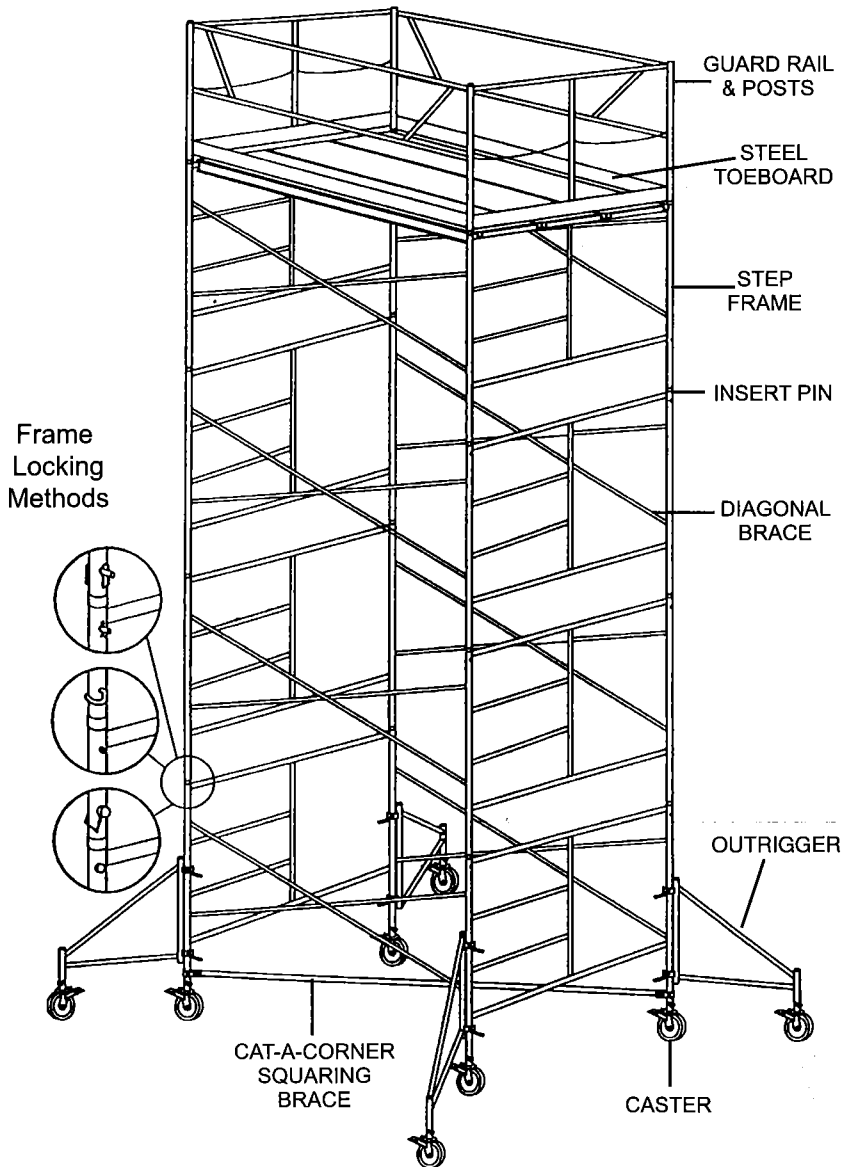
\* EXCEPTIONS: Three times in California, Ohio, Oregon, Montana and Maine.

*"These safety guidelines set forth common sense procedures for safely erecting and dismantling scaffolding equipment. However, equipment and scaffolding systems differ, and accordingly, reference must always be made to the instructions and procedures of the supplier of the equipment. Since field conditions vary and are beyond the control of the Institute, safe and proper use of scaffolding is the responsibility of the user and not the Institute."*

Reprinting of this publication does not imply approval of product by the Institute or indicate membership in the Institute. Permission to reproduce in entirety can be obtained from Scaffolding, Shoring & Forming Institute, 1230 Keith Bldg., Cleveland, Ohio 44115

# INSTRUCTIONS FOR ERECTING ROLLING OR STATIONARY TOWERS

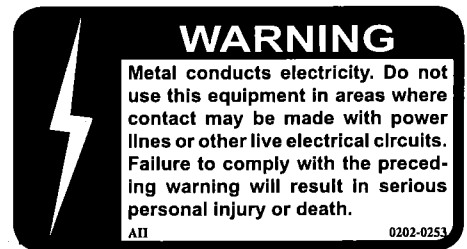
**Bil-Jax, Inc.** recommends that all users of this equipment be supplied with safety information and OSHA rules and regulations. This information must be thoroughly read and understood before using the equipment. If you have not been provided with OSHA regulations or safety literature, please call 419/445-8915 before use.



**Bil-Jax** Rolling Towers offer large work platform areas and adjustable platform levels, while providing workers with a quick, easy and safe assembly.

A Rolling Tower should only be used on solid, level and clear floor areas. Do not use on soil or unlevel surfaces. Check for overhead obstructions which may interfere with the tower.

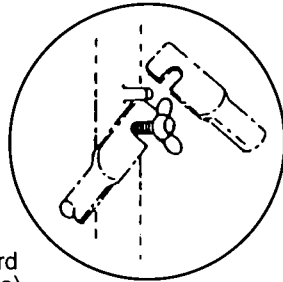
**NOTE:** Some areas may require separate access ladders or stairs. Consult your local authorities for information before beginning scaffold erection.



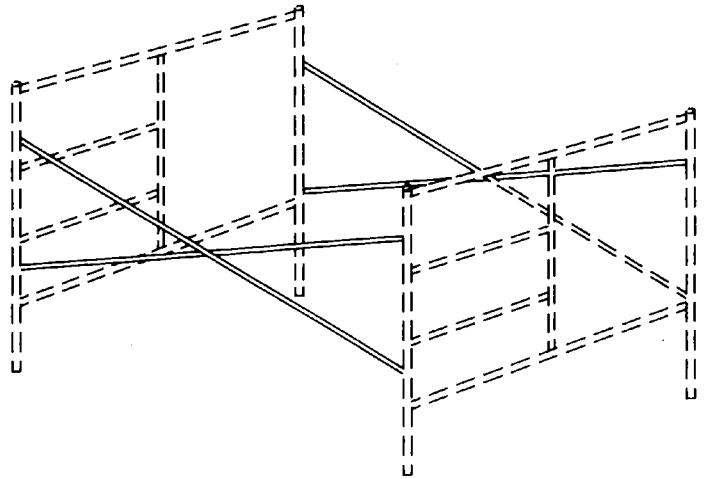
1. Before starting scaffold erection, check all parts for damage, making sure that they are in proper working order. Any part that does not look to be in good working condition or is damaged in any way should not be used.

## BRACING

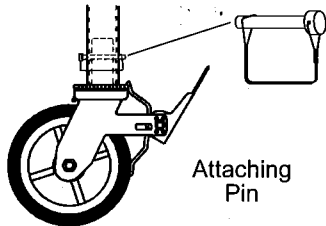
2. Attach diagonal bracing to frame sections, securing in place with the frame brace locks (Fig. 1).



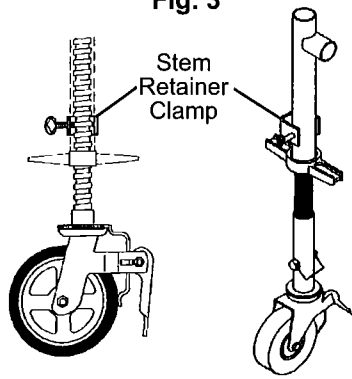
**Fig. 1**  
J-LOCK (Standard  
w/Notched Braces)



**Fig. 2**



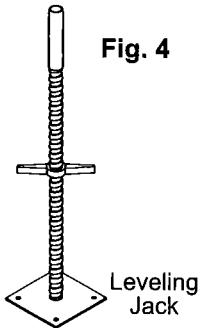
**Fig. 3**



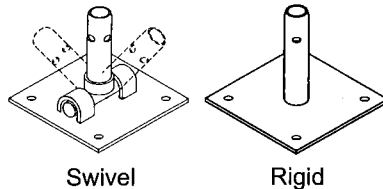
## CASTERS, JACKS, BASE PLATES

3. Insert casters and secure with attaching pin or bolt. Set brakes on all casters (Fig. 2) before proceeding with tower erection. If leveling casters or extensions are used, secure with stem retainer clamp, wire, or other suitable means (Fig. 3). Do not extend leveling screws more than 12". If application does not call for a Rolling Tower, follow above procedure and replace casters with leveling jacks (Fig. 4) or base plates (Fig. 5) on mud sills.

**Fig. 4**

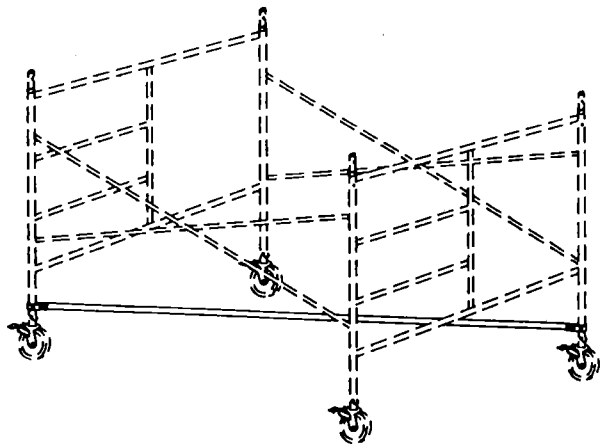
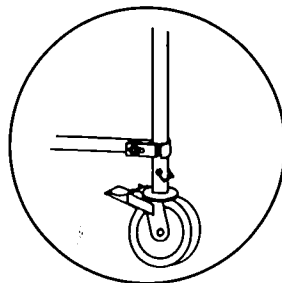


**Fig. 5**



## CAT-A-CORNER SQUARING BRACE

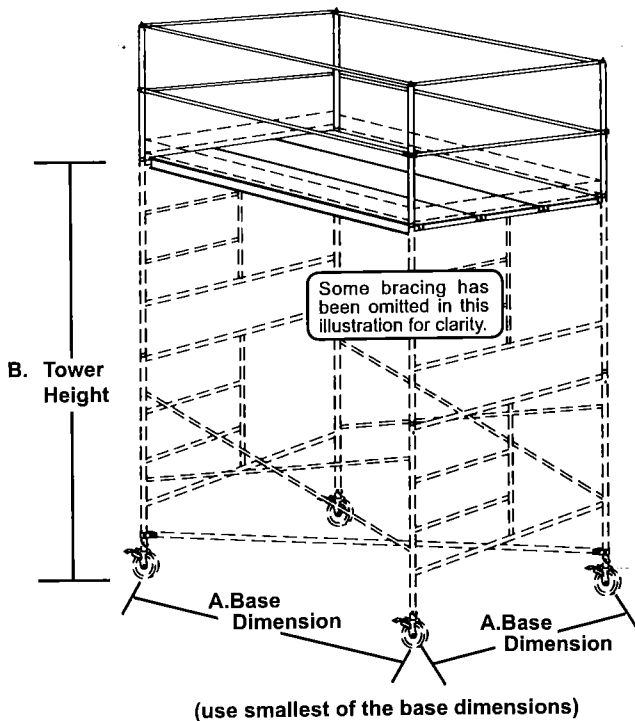
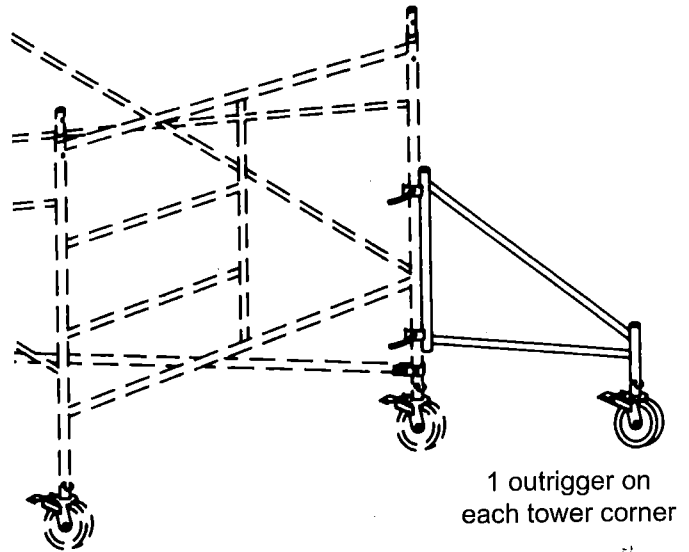
4. Install cat-a-corner squaring brace (this should be installed at the base and every additional 20' of height).





## OUTRIGGERS

5. Determine tower height required to complete the job. If height exceeds 3 times the minimum base dimension, (see Free Standing Tower Height section below) install outriggers to increase minimum base dimension or tie in to permanent structure as codes require. Pin caster to outrigger and attach outrigger to scaffold leg. Adjust to desired angle and tighten clamp firmly to prevent movement. Set caster brakes.



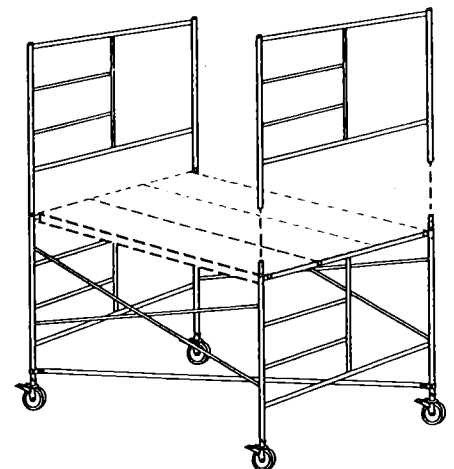
**Bil-Jax, Inc.** recommends the maximum free-standing tower height permitted for a Rolling Tower be 3 times the minimum base dimension, although OSHA codes allow 4 to 1 in most states. Consult your state and local codes to insure your tower complies with all applicable regulations.

$$A \times 3 = B$$

(smallest base dimension)      (some states allow 3-1/2 or 4—check your local & state codes)      (maximum tower height permitted)

## ADDING FRAME SECTIONS

6. Hoist end frames and braces to next level by means of rope and tag line. Install diagonal bracing. Secure frames together using inserts and insert locking pins. Be sure to erect step frames so that the steps continue above one another on the same side of the frame. Full decking should be installed on completed tier before attempting to assemble next tier, and should be moved up as each additional tier is completed.

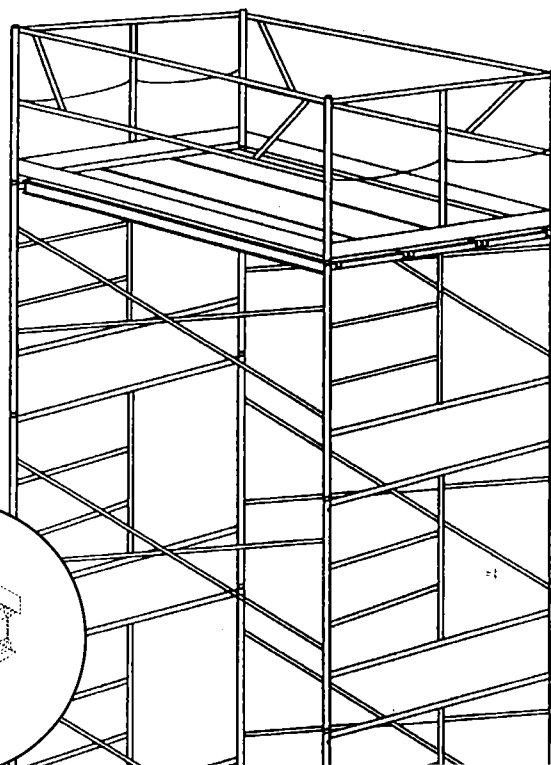
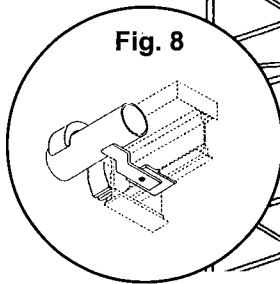
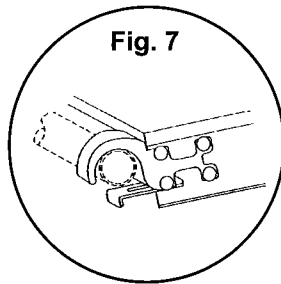
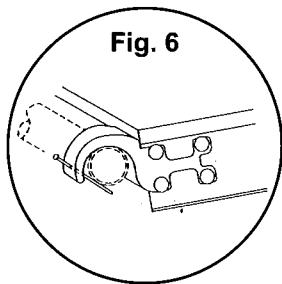


**NOTE:** When required, access ladder or stair sections must be installed at the same time as each scaffold section is added.

All photos and drawings are for illustration only. Always concerned with the improvement of the quality of this product, the manufacturer reserves the right to modify specifications without prior notice. Follow all applicable ANSI and OSHA Codes and Regulations for use of this equipment. Do not use this product in areas where user can come in contact with live power.

## **GUARD RAILING - FINAL DECKING**

7. Upon completion of tower to desired height, install and lock double guard railing and toeboards on all 4 sides as required by OSHA. Make sure all guard rail posts are secured with lock pins. Install walkboards to fully deck platform work area. Secure walkboards in place by using an 8 penny nail (Fig. 6), engaging slide lock (Fig. 7), engaging rotation lock (Fig. 8), as equipped. See OSHA regulations for additional information concerning securing decking.



### **IMPORTANT: CAUTION**

- Inspect scaffold daily or before each use.
- Do not exert horizontal force from on top of a free-standing scaffold.
- Do not climb or stand on cross braces or horizontal braces.
- Do not swing around corner of scaffold to enter platform from the cross brace side.
- Do not use boxes, ladders, or other means to increase working height.
- Do not stand or sit on guard rails.
- Do not use bricks, boxes, concrete blocks, or any other unstable objects under scaffold leg.
- **NEVER** ride a moving scaffold.
- Do not move scaffold by applying a pulling or pushing force at or near the top.
- Do not use braces as a platform support.
- Do not use personnel brackets (side brackets) on a Rolling Tower.
- Use approved access ladder or stairs to climb scaffold. Properly erected step type end frames will provide "equivalent, safe access" as required by OSHA.
- When hoisting material or using side brackets, scaffold must be restrained from tipping by guying, tying to a permanent structure or other acceptable means.
- Restrict loading to safe working loads. If unsure of safe load limit, consult your scaffold dealer.
- If you have not been provided with OSHA regulations or safety literature, or for any questions concerning the safe use of this equipment, call 419/445-8915 before use.

**NOTE:** All OSHA, state and local codes and regulations pertaining to this equipment should be obtained, read, and thoroughly understood before attempting to erect or use this equipment. Persons under the influence of drugs, alcohol, or prescription medication should not be on or near this equipment. Common sense should be implemented at all times during the erection and use of this equipment. **DO NOT USE THIS EQUIPMENT IN AREAS WHERE EQUIPMENT OR USER MAY COME IN CONTACT WITH LIVE POWER SOURCE.**

# **BIL-JAX**<sup>®</sup>

125 Taylor Parkway Archbold, OH 43502-9309  
Phone 419-445-8915 • 800-537-0540  
Fax 419-445-0367 • [www.biljax.com](http://www.biljax.com)

Reprinted from the August 30, 1996 Federal Register

## Department of Labor

Occupational Safety and Health Administration

### 29 CFR Part 1926

Safety Standards for Scaffolds Used in the Construction Industry;

Final Rule The effective date for this Standard is November 29,

1996 with some provisions effective September 27, 1997

125 Taylor Parkway, Archbold, OH 43502-9309

#### PART 1926 SUBPART L SCAFFOLDS 1926.450 SCOPE, APPLICATION AND DEFINITIONS APPLICABLE TO THIS SUBPART.

(a) **Scope and application.** This subpart applies to all scaffolds used in workplaces covered by this Part. It does not apply to crane or derrick suspended personnel platforms, which are covered by Sec. 1926.550(g). The criteria for aerial lifts are set out exclusively in Sec. 1926.453.

##### (b) Definitions

**Adjustable suspension scaffold** means a suspension scaffold equipped with a hoist(s) that can be operated by an employee(s) on the scaffold.

**Bearer (putlog)** means a horizontal transverse scaffold member (which may be supported by ledgers or runners) upon which the scaffold platform rests and which joins scaffold uprights, posts, poles, and similar members.

**Boatswain's chair** means a single-point adjustable suspension scaffold consisting of a seat or sling designed to support one employee in a sitting position.

**Body belt (safety belt)** means a strap with means both for securing it about the waist and for attaching it to a lanyard, lifeline, or deceleration device.

**Body harness** means a design of straps which may be secured about the employee in a manner to distribute the fall arrest forces over at least the thighs, pelvis, waist, chest and shoulders, with means for attaching it to other components of a personal fall arrest system.

**Brace** means a rigid connection that holds one scaffold member in a fixed position with respect to another member, or to a building or structure.

**Bricklayers' square scaffold** means a supported scaffold composed of framed squares which support a platform.

**Carpenters' bracket scaffold** means a supported scaffold consisting of a platform supported by brackets attached to building or structural walls.

**Catenary scaffold** means a suspension scaffold consisting of a platform supported by two essentially horizontal and parallel ropes attached to structural members of a building or other structure. Additional support may be provided by vertical pickups.

**Chimney hoist** means a multi-point adjustable suspension scaffold used to provide access to work inside chimneys. (See "Multi-point adjustable suspension scaffold.")

**Cleat** means a structural block used at the end of a platform to prevent the platform from slipping off its supports. Cleats are also used to provide footing on sloped surfaces such as crawling boards.

**Competent person** means one who is capable of identifying existing and predictable hazards in the surroundings or working conditions which are unsanitary, hazardous, or dangerous to employees, and who has authorization to take prompt corrective measures to eliminate them.

**Continuous run scaffold (runs scaffold)** means a two-point or multi-point adjustable suspension scaffold constructed using a series of interconnected braced scaffold members or supporting structures to form a continuous scaffold.

**Coupler** means a device for locking together the tubes of a tube and coupler scaffold.

**Crawling board (chicken ladder)** means a supported scaffold consisting of a platform with cleats spaced and secured to provide footing, for use on sloped surfaces such as roofs.

**Deceleration device** means any mechanism, such as a rope grab, rip-stitch lanyard, specially-woven lanyard, tearing or deforming lanyard, or automatic self-retracting lifeline lanyard, which dissipates a substantial amount of energy during a fall arrest or limits the energy imposed on an employee during fall arrest.

**Double pole (independent pole) scaffold** means a supported scaffold consisting of a platform(s) resting on cross beams (bearers) supported by ledgers and a double row of uprights independent of support (except ties, guys, braces) from any structure.

**Equivalent** means alternative designs, materials or methods to protect against a hazard which the employer can demonstrate will provide an equal or greater degree of safety for employees than the methods, materials or designs specified in the standard.

**Exposed power lines** means electrical power lines which are accessible to employees and which are not shielded from contact. Such lines do not include extension cords or power tool cords.

**Eye or eye splice** means a loop with or without a thimble at the end of a wire rope.

**Fabricated decking and planking** means manufactured platforms made of wood (including laminated wood and solid sawn wood planks), metal or other materials.

**Fabricated frame scaffold (tubular welded frame scaffold)** means a scaffold consisting of a platform(s) supported on fabricated end frames with integral posts, horizontal bearers, and intermediate members.

**Failure** means load refusal, breakage, or separation of component parts. Load refusal is the point where the ultimate strength is exceeded.

**Float (ship) scaffold** means a suspension scaffold consisting of a braced platform resting on two parallel bearers and hung from overhead supports by ropes of fixed length.

**Form scaffold** means a supported scaffold consisting of a platform supported by brackets attached to formwork.

**Guardrail system** means a vertical barrier consisting of, but not limited to, toprails, midrails, and posts, erected to prevent employees from falling off a scaffold platform or walkway to lower levels.

**Hoist** means a manual or power-operated mechanical device to raise or lower a suspended scaffold.

**Horse scaffold** means a supported scaffold consisting of a platform supported by construction horses (saw horses). Horse scaffolds constructed of metal are sometimes known as trestle scaffolds.

**Independent pole scaffold** (see "Double pole scaffold").

**Interior hung scaffold** means a suspension scaffold consisting of a platform suspended from the ceiling or roof structure by fixed length supports.

**Ladder jack scaffold** means a supported scaffold consisting of a platform resting on brackets attached to ladders.

**Ladder stand** means a mobile, fixed-size, self-supporting ladder consisting of a wide flat tread ladder in the form of stairs.

**Landing** means a platform at the end of a flight of stairs.

**Large area scaffold** means a pole scaffold, tube and coupler scaffold, systems scaffold, or fabricated frame scaffold erected over substantially the entire work area. For example: a scaffold erected over the entire floor area of a room.

**Lean-to scaffold** means a supported scaffold which is kept erect by tilting it toward and resting it against a building or structure.

**Lifeline** means a component consisting of a flexible line that connects to an anchorage at one end to hang vertically (vertical lifeline) or that connects to anchorages at both ends to stretch horizontally (horizontal lifeline) and which serves a means for connecting other components of a personal fall arrest system to the anchorage.

**Lower levels** means areas below the level where the employee is located and to which an employee can fall. Such areas include, but are not limited to, ground levels, floors, roofs, ramps, runways, excavations, pits, tanks, materials, water, and equipment.

**Mason's adjustable supported scaffold** (see "Self-contained adjustable scaffold").

**Mason's multi-point adjustable suspension scaffold** means a continuous run suspension scaffold designed and used for masonry operations.

**Maximum intended load** means the total load of all persons, equipment, tools, materials, transmitted loads, and other loads reasonably anticipated to be applied to a scaffold or scaffold component at any one time.

**Mobile scaffold** means a powered or unpowered, portable, caster or wheel-mounted supported scaffold.

**Multi-level suspended scaffold** means a two-point or multi-point adjustable suspension scaffold with a series of platforms at various levels resting on common stirrups.

**Multi-point adjustable suspension scaffold** means a suspension scaffold consisting of a platform(s) which is suspended by more than two ropes from overhead supports and equipped with means to raise and lower the platform to desired work levels. Such scaffolds include chimney hoists.

**Needle beam scaffold** means a platform suspended from needle beams.

**Open sides and ends** means the edges of a platform that are more than 14 inches (36cm) away horizontally from a sturdy, continuous, vertical surface (such as a building wall) or a sturdy, continuous, horizontal surface (such as a floor), or a point of access. Exception: For plastering and lathing operations the horizontal threshold distance is 18 inches (46cm).

**Outrigger** means the structural member of a supported scaffold used to increase the base width of a scaffold in order to provide support for and increased stability of the scaffold.

**Outrigger beam (Thrustout)** means the structural member of a suspension scaffold or outrigger scaffold which provides support for the scaffold by extending the scaffold point of attachment to a point out and away from the structure or building.

**Outrigger scaffold** means a support scaffold consisting of a platform resting on outrigger beams (thrustouts) projecting beyond the wall or face of the building or structure, the inboard ends of which are secured inside the building or structure.

**Overhand bricklaying** means the process of laying bricks and masonry units such that the surface of the wall to be jointed is on the opposite side of the wall from the mason, requiring the mason to lean over the wall to complete the work. It includes mason tending and electrical installation incorporated into the brick wall during the overhand bricklaying process.

**Personal fall arrest system** means a system used to arrest an employee's fall. It consists of an anchorage, connectors, a body belt or body harness and may include a lanyard deceleration device, lifeline, or combinations of these.

**Platform** means a work surface elevated above lower levels. Platforms can be constructed using individual wood planks, fabricated planks, fabricated decks, and fabricated platforms.

**Pole scaffold** [see definitions for "Single-pole scaffold" and "Double (independent) pole scaffold"].

**Power operated hoist** means a hoist which is powered by other than human energy.

**Pump jack scaffold** means a supported scaffold consisting of a platform supported by vertical poles and movable support brackets.

**Qualified** means one who, by possession of a recognized degree, certificate, or professional standing, or who by extensive knowledge, training, and experience, has successfully demonstrated his/her ability to solve or resolve problems related to the subject matter, the work, or the project.

**Rated load** means the manufacturer's specified maximum load to be lifted by a hoist or to be applied to a scaffold or scaffold component.

**Repair bracket scaffold** means a supported scaffold consisting of a platform supported by brackets which are secured in place around the circumference or perimeter of a chimney, stack, tank, or other supporting structure by one or more wire ropes placed around the supporting structure.

**Roof bracket scaffold** means a rooftop supported scaffold consisting of a platform resting on angular-shaped supports.

**Runner (ledger or ribbon)** means the lengthwise horizontal spacing or bracing member which may support the bearers.

**Scaffold** means any temporary elevated platform (supported or suspended) and its supporting structure (including points of anchorage), used for supporting employees or materials or both.

**Self-contained adjustable scaffold** means a combination supported and suspension scaffold consisting of an adjustable platform(s) mounted on an independent supporting frame(s) not a part of the object being worked on and which is equipped with a means to permit the raising and lowering of the platform(s). Such systems include rolling roof rigs, rolling outrigger systems, and some masons' adjustable supported scaffolds.

**Shore scaffold** means a supported scaffold which is placed against a building or structure and held in place with props.

**Single point adjustable suspension scaffold** means a suspension scaffold consisting of a platform suspended by one rope from an overhead support and equipped with means to permit the movement of the platform to desired work levels.

**Single-pole scaffold** means a supported scaffold consisting of a platform(s) resting on bearers, the outside ends of which are supported on runners secured to a single row of posts or uprights, and the inner ends of which are supported on or in a structure or building wall.

**Stair tower (Scaffold stairway/tower)** means a tower comprised of scaffold components and which contains internal stairway units and rest platforms. These towers are used to provide access to scaffold platforms and other elevated points such as floors and roofs.

**Stall load** means the load at which the prime-mover of a power operated hoist stalls or the power to the prime-mover is automatically disconnected.

**Step, platform, and trestle ladder scaffold** means a platform resting directly on the rungs of step ladders or trestle ladders.

**Stifts** means a pair of poles or similar supports with raised footrests used to permit walking above the ground or working surface.

**Stonesetters' multi-point adjustable suspension scaffold** means a continuous run suspension scaffold designed and used for stonesetters' operations.

**Supported scaffold** means one or more platforms supported by outrigger beams, brackets, poles, legs, uprights, posts, frames, or similar rigid support.

**Suspension scaffold** means one or more platforms suspended by ropes or other non-rigid means from an overhead structure(s).

**System Scaffold** means a scaffold consisting of posts with fixed connection points that accept runners, bearers, and diagonals that can be interconnected at predetermined levels.

**Tank builders' scaffold** means a supported scaffold consisting of a platform resting on brackets that are either directly attached to a cylindrical tank or attached to devices that are attached to such a tank.

**Top plate bracket scaffold** means a scaffold supported by brackets that hook over or are attached to the top of a wall. This type of scaffold is similar to carpenters' bracket scaffolds and form scaffolds and is used in residential construction for setting trusses.

**Tube and coupler scaffold** means a supported or suspended scaffold consisting of a platform(s) supported by tubing, erected with coupling devices connecting uprights, braces, bearers, and runners.

**Tubular welded frame scaffold** (see "Fabricated frame scaffold").

**Two-point suspension scaffold (swing stage)** means a suspension scaffold consisting of a platform supported by hangers (stirrups) suspended by two ropes from overhead supports and equipped with the means to permit the raising and lowering of the platform to desired work levels.

**Unstable objects** means items whose strength, configuration, or lack of stability may allow them to become dislocated and shift and therefore may not properly support the loads imposed on them. Unstable objects do not constitute a safe base support for scaffolds, platforms, or employees. Examples

include, but are not limited to, barrels, boxes, loose brick, and concrete blocks.

**Vertical pickup** means a rope used to support the horizontal rope in catenary scaffold.

**Walkway** means a portion of a scaffold platform used only for access and not as a work level.

**Window jack scaffold** means a platform resting on a bracket or jack which projects through a window opening.

## 1926.451 GENERAL REQUIREMENTS

This section does not apply to aerial lifts, the criteria for which are set out exclusively in Sec. 1926.453.

### (a) Capacity

(1) Except as provided in paragraphs (a) (2), (a) (3), (a) (4), (a) (5), and (g) of this section, each scaffold and scaffold component shall be capable of supporting, without failure, its own weight and at least 4 times the maximum intended load applied or transmitted to it.

(2) Direct connections to roofs and floors, and counterweights used to balance adjustable suspension scaffolds, shall be capable of resisting at least 4 times the tipping moment imposed by the scaffold operating at either the rated load of the hoist, or 1.5 (minimum) times the tipping moment imposed by the scaffold operating at the stall load of the hoist, whichever is greater.

(3) Each suspension rope, including connecting hardware, used on non-adjustable suspension scaffolds shall be capable of supporting, without failure, at least 6 times the maximum intended load applied or transmitted to that rope.

(4) Each suspension rope, including connecting hardware, used on adjustable suspension scaffolds shall be capable of supporting, without failure, at least 6 times the maximum intended load applied or transmitted to that rope with the scaffold operating at either the rated load of the hoist, or 2 (minimum) times the stall load of the hoist, whichever is greater.

(5) The stall load of any scaffold hoist shall not exceed 3 times its rated load.

(6) Scaffolds shall be designed by a qualified person and shall be constructed and loaded in accordance with that design. Non-mandatory Appendix A to this subpart contains examples of criteria that will enable an employer to comply with paragraph (a) of this section.

### (b) Scaffold Platform construction.

(1) Each platform on all working levels of scaffolds shall be fully planked or decked between the front uprights and the guardrail supports as follows:

(i) Each platform unit (e.g., scaffold plank, fabricated plank, fabricated deck, or fabricated platform) shall be installed so that the space between adjacent units and the space between the platform and the uprights is no more than 1 inch (2.5cm) wide, except where the employer can demonstrate that a wider space is necessary (for example, to fit around uprights when side brackets are used to extend the width of the platform).

(ii) Where the employer makes the demonstration provided for in paragraph (b)(1)(i) of this section, the platform shall be planked or decked as fully as possible and the remaining open space between the platform and the uprights shall not exceed 9-1/2 inches (24.1 cm).

**Exception to paragraph (b) (1):** The requirement in paragraph (b) (1) to provide full planking or decking does not apply to platforms used solely as walkways or solely by employees performing scaffold erection or dismantling. In these situations, only the planking that the employer establishes is necessary to provide safe working conditions is required.

(2) Except as provided in paragraphs (b)(2)(i) and (b)(2)(ii) of this section, each scaffold platform and walkway shall be at least 18 inches (46 cm) wide.

(i) Each ladder jack scaffold, top plate bracket scaffold, roof bracket, and pump jack scaffold shall be at least 12 inches (30 cm) wide. There is no minimum width requirement for boatswains' chairs.

(ii) Where scaffolds must be used in areas that the employer can demonstrate are so narrow that platforms and walkways cannot be at least 18 inches (46 cm) wide, such platforms and walkways shall be as wide as feasible, and employees on those platforms and walkways shall be protected from fall hazards by the use of guardrails and/or personal fall arrest systems.

(3) Except as provided in paragraphs (b) (3) (i) and (ii) of this section, the front edge of all platforms shall not be more than 14 inches (36 cm) from the face of the work, unless guardrail systems are erected along the front edge and/or personal fall arrest systems are used in accordance with paragraph (g) of this section to protect employees from falling.

(i) The maximum distance from the face for outrigger scaffolds shall be 3 inches (8 cm).

(ii) The maximum distance from the face for plastering and lathing operations shall be 18 inches (46 cm).

(4) Each end of a platform, unless cleated or otherwise restrained by hooks or equivalent means, shall extend over the centerline of its support at least 6 inches (15 cm).

(5)(i) Each end of a platform 10 feet or less in length shall not extend over its support more than 12 inches (30 cm) unless the platform is designed and installed so that the cantilevered portion of the platform is able to support employees and/or materials without tipping, or has guardrails which block employee access to the cantilevered end.

(ii) Each platform greater than 10 feet in length shall not extend over its support more than 18 inches (46 cm), unless it is designed and installed so that the cantilevered portion of the platform is able to support employees without tipping, or has guardrails which block employee access to the cantilevered

end.

(6) On scaffolds where scaffold planks are abutted to create a long platform, each abutted end shall rest on a separate support surface. This provision does not preclude the use of common support members, such as "T" sections, to support abutting planks, or hook on platforms designed to rest on common supports.

(7) On scaffolds where platforms are overlapped to create a long platform, the overlap shall occur only over supports, and shall not be less than 12 inches (30 cm) unless the platforms are nailed together or otherwise restrained to prevent movement.

(8) At all points of a scaffold where the platform changes direction, such as turning a corner, any platform that rests on a bearer at an angle other than a right angle shall be laid first, and platforms which rest at right angles over the same bearer shall be laid second, on top of the first platform.

(9) Wood platforms shall not be covered with opaque finishes, except that platform edges may be covered or marked for identification. Platforms may be coated periodically with wood preservatives, fire-retardant finishes, and slip-resistant finishes; however, the coating may not obscure the top or bottom wood surfaces.

(10) Scaffold components manufactured by different manufacturers shall not be intermixed unless the components fit together without force and the scaffold's structural integrity is maintained by the user. Scaffold components manufactured by different manufacturers shall not be modified in order to intermix them unless a competent person determines the resulting scaffold is structurally sound.

(11) Scaffold components made of dissimilar metals shall not be used together unless a competent person has determined that galvanic action will not reduce the strength of any component to a level below that required by paragraph (a) (1) of this section.

Maximum intended nominal load (lb/ft <sup>2</sup> )	Maximum permissible span using full thickness undressed lumber (ft)	Maximum permissible span using nominal thickness lumber (ft)
25	10	8
50	8	6
75	6	--

**(c) Criteria for supported scaffolds.**

(1) Supported scaffolds with a height to base width (including outrigger supports, if used) ratio of more than four to one (4:1) shall be restrained from tipping by guying, tying, bracing, or equivalent means, as follows:

(i) Guys, ties, and braces shall be installed at locations where horizontal members support both inner and outer legs.

(ii) Guys, ties, and braces shall be installed according to the scaffold manufacturer's recommendations or at the closest horizontal member to the 4:1 height and be repeated vertically at locations of horizontal members every 20 feet (6.1 m) or less thereafter for scaffolds 3 feet (0.91 m) wide or less and every 26 feet (7.9 m) or less thereafter for scaffolds greater than 3 feet (0.91 m) wide. The top guy, tie or brace of completed scaffolds shall be placed no further than the 4:1 height from the top. Such guys, ties, and braces shall be installed at each end of the scaffold and at horizontal intervals not to exceed 30 feet (9.1 m) (measured from one end [not both] towards the other).

(iii) Ties, guys, braces, or outriggers shall be used to prevent the tipping of supported scaffolds in all circumstances where an eccentric load, such as a cantilevered work platform, is applied or is transmitted to the scaffold.

(2) Supported scaffold poles, legs, posts, frames, and uprights shall bear on base plates and mud sills, or other adequate firm foundation.

(i) Footings shall be level, sound, rigid, and capable of supporting the loaded scaffold without settling or displacement.

(ii) Unstable objects shall not be used to support scaffolds or platform units.

(iii) Unstable objects shall not be used as working platforms.

(iv) Front-end loaders and similar pieces of equipment shall not be used to support scaffold platforms unless they have been specifically designed by the manufacturer for such use.

(v) Fork-lifts shall not be used to support scaffold platforms unless the entire platform is attached to the fork and the fork-lift is not moved horizontally while the platform is occupied.

(3) Support scaffold poles, legs, posts, frames, and uprights shall be plumb and braced to prevent swaying and displacement.

**(e) Access.** This paragraph applies to scaffold access for all employees. Access requirements for employees erecting or dismantling supported scaffolds are specifically addressed in paragraph (e) (9) of this section.

(1) When scaffold platforms are more than 2 feet (0.6 m) above or below a point of access, portable ladders, hook-on ladders, attachable ladders, stair towers (scaffold stairways/towers), stairway-type ladders (such as ladder stands), ramps, walkways, integral prefabricated scaffold access, or direct access from another scaffold, structure, personnel hoist, or similar surface shall be used. Crossbraces shall not be used as a means of access.

(2) Portable, hook-on, and attachable ladders (Additional requirements for the proper construction and use of portable ladders are contained in Subpart X of this part - Stairways and Ladders):

(i) Portable, hook-on, and attachable ladders shall be positioned so as not to tip the scaffold.

(ii) Hook-on and attachable ladders shall be positioned so that their bottom rung is not more than 24 inches (61 cm) above the scaffold supporting level;

(iii) When hook-on and attachable ladders are used on a supported scaffold more than 35 feet (10.7 m) high, they shall have rest platforms at 35-foot (10.7 m)

maximum vertical intervals.

(iv) Hook-on and attachable ladders shall be specifically designed for use with the type of scaffold used;

(v) Hook-on and attachable ladders shall have a minimum rung length of 11-1/2 inches (29 cm); and

(vi) Hook-on and attachable ladders shall have uniformly spaced rungs with a maximum spacing between rungs of 16-3/4 inches.

(3) Stairway-type ladders shall:

(i) Be positioned such that their bottom step is not more than 24 inches (61 cm) above the scaffold supporting level;

(ii) Be provided with rest platforms at 12 foot (3.7 m) maximum vertical intervals;

(iii) Have a minimum step width of 16 inches (41 cm), except that mobile scaffold stairway-type ladders shall have a minimum step width of 11-1/2 inches (30 cm); and

(iv) have slip-resistant treads on all steps and landings.

(4) Stairtowers (scaffold stairway/towers) shall be positioned such that their bottom step is not more than 24 inches (61 cm) above the scaffold supporting level.

(i) A stairrail consisting of a toprail and a midrail shall be provided on each side of each scaffold stairway.

(ii) The toprail of each stairrail system shall also be capable of serving as a handrail, unless a separate handrail is provided.

(iii) Handrails, and toprails that serve as handrails, shall provide an adequate handhold for employees grasping them to avoid falling.

(iv) Stairrail systems and handrails shall be surfaced to prevent injury to employees from punctures or lacerations, and to prevent snagging of clothing.

(v) The ends of stairrail systems and handrails shall be constructed so that they do not constitute a projection hazard.

(vi) Handrails, and toprails that are used as handrails, shall be at least 3 inches (7.6 cm) from other objects.

(vii) Stairrails shall be not less than 28 inches (71 cm) nor more than 37 inches (94 cm) from the upper surface of the stairrail to the surface of the tread, in line with the face of the riser at the forward edge of the tread.

(viii) A landing platform at least 18 inches (45.7 cm) wide by at least 18 inches (45.7 cm) long shall be provided at each level.

(ix) Each scaffold stairway shall be at least 18 inches (45.7 cm) wide between stairrails.

(x) Treads and landings shall have slip-resistant surfaces.

(xi) Stairways shall be installed between 40 degrees and 60 degrees from the horizontal.

(xii) Guardrails meeting the requirements of paragraph (g)(4) of this section shall be provided on the open sides and ends of each landing.

(xiii) Riser height shall be uniform, within 1/4 inch, (0.6 cm) for each flight of stairs. Greater variations in riser height are allowed for the top and bottom steps of the entire system, not for each flight of stairs.

(xiv) Tread depth shall be uniform, within 1/4 inch, for each flight of stairs.

(5) Ramps and walkways.

(i) Ramps and walkways 6 feet (1.8 m) or more above lower levels shall have guardrail systems which comply with Subpart M of this part - Fall Protection;

(ii) No ramp or walkway shall be inclined more than a slope of one (1) vertical to three (3) horizontal (20 degrees above the horizontal).

(iii) If the slope of a ramp or walkway is steeper than one (1) vertical in eight (8) horizontal, the ramp or walkway shall have cleats not more than fourteen (14) inches (35 cm) apart which are securely fastened to the planks to provide footing.

(6) Integral prefabricated scaffold access frames shall:

(i) Be specifically designed and constructed for use as ladder rungs;

(ii) Have a rung length of at least 8 inches (20 cm);

(iii) Not be used as work platforms when rungs are less than 11-1/2 inches in length, unless each affected employee uses fall protection or a positioning device, which complies with Sec. 1926.502;

(vi) Be uniformly spaced within each frame section;

(v) Be provided with rest platforms at 35-foot (10.7 m) maximum vertical intervals on all supported scaffolds more than 35 feet (10.7 m) high; and

(vi) Have a maximum spacing between rungs of 16-3/4 inches (43 cm). Non-uniform rung spacing caused by joining end frames together is allowed, provided the resulting spacing does not exceed 16-3/4 inches (43 cm).

(7) Steps and rungs of ladder and stairway type access shall line up vertically with each other between rest platforms.

(8) Direct access to or from another surface shall be used only when the scaffold is not more than 14 inches (36 cm) horizontally and not more than 24 inches (61 cm) vertically from the other surface.

(9) Effective September 2, 1997, access for employees erecting or dismantling supported scaffolds shall be in accordance with the following:

(i) The employer shall provide safe means of access for each employee erecting or dismantling a scaffold where the provision of safe access is feasible and does not create a greater hazard. The employer shall have a competent person determine whether it is feasible or would pose a greater hazard to provide, and have employees use a safe means of access. This determination shall be based on site conditions and the type of scaffold being erected or dismantled.

(ii) Hook-on or attachable ladders shall be installed as soon as scaffold erection has progress to a point that permits safe installation and use.

(iii) When erecting or dismantling tubular welded frame scaffolds, (end) frames, with horizontal members that are parallel, level and are not more than 22 inches apart vertically may be used as climbing devices for access, provided they are erected in a manner that creates a usable ladder and provides good hand hold and foot space.

(iv) Cross braces on tubular welded frame scaffolds shall not be used as a means of access or egress.

**(f) Use.**

(1) Scaffolds and scaffold components shall not be loaded in excess of their maximum intended loads or rated capacities, whichever is less.

(2) The use of shore or lean-to scaffolds is prohibited.

(3) Scaffolds and scaffold components shall be inspected for visible defects by a competent person before each work shift, and after any occurrence which could affect a scaffold's structural integrity.

(4) Any part of a scaffold damaged or weakened such that its strength is less than that required by paragraph (a) of this section shall be immediately repaired or replaced, braced to meet those provisions, or removed from service until repaired.

(5) Scaffolds shall not be moved horizontally while employees are on them, unless they have been designed by a registered professional engineer specifically for such movement or, for mobile scaffolds, where the provisions of Sec. 1926.452 (w) are followed.

(6) The clearance between scaffolds and power lines shall be as follows: Scaffolds shall not be erected, used, dismantled, altered, or moved such that they or any conductive material handled on them might come closer to exposed and energized power lines than as follows:

Insulated lines voltage	Minimum Distance	Alternatives
Less than 300 Volts	3 Feet (0.9 M)	
300 Volts to 50 kv	10 Feet (3.1 M)	
More than 50 kv	10 Feet (3.1 M)	2 times the length of the line insulator, but never less than 10 Feet (3.1 M)

Uninsulated lines voltage	Minimum Distance	Alternatives
Less than 50 kv	10 Feet (3.1 M)	
More than 50 kv	10 Feet (3.1 M) plus 40 inches (10 cm) for each 1 kn over 50 kv.	2 times the length of the line insulator, but never less than 10 Feet (3.1 M)

**Exception to paragraph (f)(6):** Scaffolds and materials may be closer to power lines than specified above where such clearance is necessary for performance of work, and only after the utility company, or electrical system operator, has been notified of the need to work closer and the utility company, or electrical system operator, has deenergized the lines, relocated the lines, or installed protective coverings to prevent accidental contact with the lines.

(7) Scaffolds shall be erected, moved, dismantled, or altered only under the supervision and direction of a competent person qualified in scaffold erection, moving, dismantling or alterations. Such activities shall be performed only by experienced and trained employees selected for such work by the competent person.

(8) Employees shall be prohibited from working on scaffolds covered with snow, ice, or other slippery material except as necessary for removal of such materials.

(9) Where swinging loads are being hoisted onto or near scaffolds such that the loads might contact the scaffold, tag lines or equivalent measures to control the loads shall be used.

(10) Suspension ropes supporting adjustable suspension scaffolds shall be of a diameter large enough to provide sufficient surface area for the functioning of brake and hoist mechanisms.

(11) Suspension ropes shall be shielded from heat producing processes. When acids or other corrosive substances are used on a scaffold, the ropes shall be shielded, treated to protect against the corrosive substances, or shall be of material that will not be damaged by the substance being used.

(12) Work on or from scaffolds is prohibited during storms or high winds unless a competent person has determined that it is safe for employees to be on the scaffold and those employees are protected by a personal fall arrest system or wind screens. Wind screens shall not be used unless the scaffold is secured against the anticipated wind forces imposed.

(13) Debris shall not be allowed to accumulate on platforms.

(14) Makeshift devices, such as but not limited to boxes and barrels, shall not be used on top of scaffold platforms to increase the working level height of employees.

(15) Ladders shall not be used on scaffolds to increase the working level height of employees, except on large area scaffolds where employers have satisfied the following criteria:

(i) When the ladder is placed against a structure which is not a part of the scaffold, the scaffold shall be secured against the sideways thrust exerted by the ladder;

(ii) The platform units shall be secured to the scaffold to prevent their movement;

(iii) The ladder legs shall be on the same platform or other means shall be provided to stabilize the ladder against unequal platform deflection, and

(iv) The ladder legs shall be secured to prevent them from slipping or being pushed off the platform.

(16) Platforms shall not deflect more than 1/60 of the span when loaded.

(17) To reduce the possibility of welding current arcing through the suspension wire rope when performing welding from suspended scaffolds, the following precautions shall be taken, as applicable:

(i) An insulated thimble shall be used to attach each suspension wire rope to its hanging support (such as cornice hook or outrigger). Excess suspension wire rope and any additional independent lines from grounding shall be insulated.

(ii) The suspension wire rope shall be covered with insulating material extending at least 4 feet (1.2m) above the hoist. If there is a tail line below the hoist, it shall be insulated to prevent contact with the platform. The portion of the tail line that hangs free below the scaffold shall be guided or retained, or both, so that it does not become grounded.

(iii) Each hoist shall be covered with insulated protective covers;

(iv) In addition to a work lead attachment required by the welding process, a grounding conductor shall be connected from the scaffold to the structure. The size of this conductor shall be at least the size of the welding process work lead, and this conductor shall not be in series with the welding process or the work piece;

(v) If the scaffold grounding lead is disconnected at any time, the welding machine shall be shut off; and

(vi) An active welding rod or uninsulated welding lead shall not be allowed to contact the scaffold or its suspension system.

**(g) Fall protection.**

(1) Each employee on a scaffold more than 10 feet (3.1m) above a lower level shall be protected from falling to that lower level. Paragraphs (g)(1)(i) through (vii) of this section establish the types of fall protection to be provided to the employees on each type of scaffold. Paragraph (g)(2) of this section addresses fall protection for scaffold erectors and dismantlers.

Note to paragraph (g)(1): The fall protection requirements for employees installing suspension scaffold support systems on floors, roofs, and other elevated surfaces are set for the in Subpart M of this part.

(i) Each employee on a boatswain's chair, catenary scaffold, float scaffold, needle beam scaffold, or ladder jack scaffold shall be protected by a personal fall arrest system;

(ii) Each employee on a single-point or two-point adjustable suspension scaffold shall be protected by both a personal fall arrest system and guardrail system;

(iii) Each employee on a crawling board (chick ladder) shall be protected by a personal fall arrest system, a guardrail system (with minimum 200 pound toprail capacity), or by a three-fourth inch (1.9cm) diameter grabline or equivalent handhold securely fastened beside each crawling board;

(iv) Each employee on a self-contained adjustable scaffold shall be protected by a guardrail system (with minimum 200 pound toprail capacity) when the platform is supported by the frame structure, and by both a personal fall arrest system and a guardrail system (with minimum 200 pound toprail capacity) when the platform is supported by ropes;

(v) Each employee on a walkway located within a scaffold shall be protected by a guardrail system (with minimum 200 pound toprail capacity) installed within 9-1/2 inches (24.1cm) of and along at least one side of the walkway.

(vi) Each employee performing overhand bricklaying operations from a supported scaffold shall be protected from falling from all open sides and ends of the scaffold (except at the side next to the wall being laid) by the use of a personal fall arrest system or guardrail system (with minimum 200 pound toprail capacity).

(vii) For all scaffolds not otherwise specified in paragraphs (g)(1)(i) through (g)(1)(vi) of this section, each employee shall be protected by the use of personal fall arrest systems or guardrails systems meeting the requirements of paragraph (g)(4) of this section.

(2) Effective September 2, 1997, the employer shall have a competent person determine the feasibility and safety of providing fall protection for employees erecting or dismantling supported scaffolds. Employers are required to provide fall protection for employees erecting or dismantling supported scaffolds where the installation and use of such protection is feasible and does not create a greater hazard.

(3) In addition to meeting the requirements of Sec. 1926.502(d), personal fall arrest systems used on scaffolds shall be attached by lanyard to vertical lifeline, horizontal lifeline, or scaffold structural member. Vertical lifelines shall not be used when overhead components, such as overhead protection or additional platform levels, are part of a single-point or two-point adjustable suspension scaffold.

(i) When vertical lifelines are used, they shall be fastened to a fixed safe point of anchorage, shall be independent of the scaffold,



and shall be protected from sharp edges and abrasion. Safe points of anchorage include structural members of buildings, but do not include standpipes, vents, or other piping systems, electrical conduit, outrigger beams, or counterweights.

(ii) When horizontal lifelines are used, they shall be secured to two or more structural members of the scaffold, or they may be looped around both suspension and independent suspension lines (on scaffolds so equipped) above the hoist and brake attached to the end of the scaffold. Horizontal lifelines shall not be attached only to the suspension ropes.

(iii) When lanyards are connected to horizontal lifelines or structural members on a single-point or two-point adjustable suspension scaffold, the scaffold shall be equipped with additional independent support lines and automatic locking devices capable of stopping the fall of the scaffold in the event one or both of the suspension ropes fail. The independent support lines shall be equal in number and strength to the suspension ropes.

(vi) Vertical lifelines, independent support lines, and suspension ropes shall not be attached to each other, nor shall they be attached to or use the same point of anchorage, nor shall they be attached to the same point on the scaffold or personal fall arrest system.

(4) Guardrail systems installed to meet the requirements of this section shall comply with the following provisions (guardrail systems built in accordance with Appendix A to this subpart will be deemed to meet the requirements of paragraphs (g)(4)(vii), and (ix) of this section):

(i) Guardrail systems shall be installed along all open sides and ends of platforms. Guardrail systems shall be installed before the scaffold is released for use by employees other than erection/dismantling crews.

(ii) The top edge height of toprails or equivalent member on supported scaffolds manufactured or placed in service after January 1, 2000 shall be installed between 38 inches (0.97m) and 45 inches (1.2m) above the platform surface. The top edge height on supported scaffolds manufactured and placed in service before January 1, 2000, and on all suspended scaffolds where both a guardrail and a personal fall arrest system are required shall be between 36 inches (0.9m) and 45 inches (1.2m). When conditions warrant, the height of the top edge may exceed the 45-inch height, provided the guardrail system meets all other criteria of paragraph (g)(4).

(iii) When midrails, screens, mesh, intermediate vertical members, solid panels, or equivalent structural members are used, they shall be installed between the top edge of the guardrail system and the scaffold platform.

(iv) When midrails are used, they shall be installed at a height approximately midway between the top edge of the guardrail system and the platform surface.

(v) When screens and mesh are used, they shall extend from the top edge of the guardrail system to the scaffold platform, and along the entire opening between the supports.

(vi) When intermediate members (such as balusters or additional rails) are used, they shall not be more than 19 inches (49cm) apart.

(vii) Each toprail or equivalent member of a guardrail system shall be capable of withstanding, without failure, a force applied in any downward or horizontal direction at any point along its top edge of at least 100 pounds (445n) for guardrail systems installed on single-point adjustable suspension scaffolds or two-point adjustable suspension scaffolds, and at least 200 pounds (890n) for guardrail systems installed on all other scaffolds.

(viii) When the loads specified in paragraph (g)(4)(vii) of this section are applied in a downward direction, the top edge shall not drop below the height above the platform surface that is prescribed in paragraph (g)(4)(ii) of this section.

(ix) Midrails, screens, mesh, intermediate vertical members, solid panels, and equivalent structural members of a guardrail system shall be capable of withstanding, without failure, a force applied in any downward or horizontal direction at any point along with the midrail or other member of at least 75 pounds (333n) for guardrail systems with a minimum 100 pound toprail capacity, and at least 150 pounds (660n) for guardrail systems with a minimum 200 pound toprail capacity.

(x) Suspension scaffold hoists and non-walk-through stirrups may be used as end guardrails, if the space between the hoist or stirrup and the side guardrail or structure does not allow passage of an employee to the end of the scaffold.

(xi) Guardrails shall be surfaced to prevent injury to an employee from punctures or lacerations, and to prevent snagging of clothing.

(xii) The ends of rails shall not overhang the terminal posts except when such overhang does not constitute a projection hazard to employees.

(xiii) Steel or plastic banding shall not be used as a toprail or midrail.

(xiv) Manila or plastic (or other synthetic) rope being used for

toprails or midrails shall be inspected by a competent person as frequently as necessary to ensure that it continues to meet the strength requirements of paragraph (g) of this section.

(xv) Crossbracing is acceptable in place of a midrail when the crossing point of two braces is between 20 inches (0.5m) and 30 inches (0.8m) above the work platform or as a toprail when the crossing point of two braces is between 38 inches (0.97m) and 48 inches (1.3m) above the work platform. The end points at each upright shall be no more than 48 inches (1.3m) apart.

(h) **Falling object protection.**

(1) In addition to wearing hard-hats, each employee on a scaffold shall be provided with additional protection from falling hand tools, debris, and other small objects through the installation of toeboards, screens, or guardrail systems, or through the erection of debris nets, catch platforms, or canopy structures that contain or deflect the falling objects. When the falling objects are too large, heavy or massive to be contained or deflected by any of the above-listed measures, the employer shall place such potential falling objects away from the edge of the surface from which they could fall and shall secure those materials as necessary to prevent their falling.

(2) Where there is a danger of tools, materials, or equipment falling from a scaffold and striking employees below, the following provisions apply.

(i) The area below the scaffold to which objects can fall shall be barricaded, and employees shall not be permitted to enter the hazard area; or

(ii) A toeboard shall be erected along the edge of platforms more than 10 feet (3.1m) above lower levels for a distance sufficient to protect employees below, except on float (ship) scaffolds where an edging of 3/4 x 1-1/2 inch (2 x 4cm) wood or equivalent may be used in lieu of toeboards;

(iii) Where tools, materials, or equipment are piled to a height higher than the top edge of the toeboard, paneling or screening extending from the toeboard or platform to the top of the guardrail shall be erected for a distance sufficient to protect employees below; or

(iv) A guardrail system shall be installed with openings small enough to prevent passage of potential falling objects; or

(v) A canopy structure, debris net, or catch platform strong enough to withstand the impact forces of the potential falling objects shall be erected over the employees below.

(3) Canopies, when used for falling object protection, shall comply with the following criteria:

(i) Canopies shall be installed between the falling object hazard and the employees.

(ii) When canopies are used on suspension scaffolds for falling object protection, the scaffold shall be equipped with additional independent support lines equal in number to the number of points supported, and equivalent in strength to the strength of the suspension ropes.

(iii) Independent support lines and suspension ropes shall not be attached to the same point of anchorage.

(4) Where used, toeboards shall be:

(i) Capable of withstanding, without failure, a force of at least 50 pounds (222n) applied in any downward or horizontal direction at any point along the toeboard (toeboards built in accordance with Appendix A to this subpart will be deemed to meet this requirement); and

(ii) At least three and one-half inches (9 cm) high from the top edge of the toeboard to the level of the walking/working surface. Toeboards shall be securely fastened in place at the out most edge of the platform and have not more than 1/4 inch (0.7cm) clearance above the walking/working surface. Toeboards shall be solid or with openings not over one inch (2.5cm) in the greatest dimension.

#### **1926.452 ADDITIONAL REQUIREMENTS APPLICABLE TO SPECIFIC TYPES OF SCAFFOLDS.**

In addition to the applicable requirements of Sec. 1926.451, the following requirements may apply to the specific types of scaffolds indicated. Scaffolds not specifically addressed by Sec. 1926.452, such as but not limited to systems scaffolds, must meet the requirements of Sec. 1926.451.

(b) **Tube and coupler scaffolds.**

(1) When platforms are being moved to the next level, the existing platform shall be left undisturbed until the new bearers have been set in place and braced prior to receiving the new platforms.

(2) Traverse bracing forming an "X" across the width of the scaffold shall be installed at the scaffold ends and at least every third set of posts horizontally (measured from only one end) and every fourth runner vertically. Bracing shall extend diagonally from the inner or outer posts or runners upward to the next outer or inner posts or runners. Building ties shall be installed at the bearer levels between the transverse bracing and shall conform to the requirements of Sec. 1926.451(c)(1);

(3) On straight run scaffolds, longitudinal bracing across the inner and outer rows of posts shall be installed diagonally in both directions, and shall be installed diagonally in both directions, and shall extend from the base of the end posts upward to the top of the scaffold at approximately a 45 degree angle. On scaffolds whose length is greater than their height, such bracing shall be repeated beginning at least at every fifth post. On scaffolds whose length is less than their height, such bracing shall be installed from the base of the end posts upward to the opposite end posts and then in alternating directions until reaching the top of the scaffold. Bracing shall be installed as close as possible to the intersection of the bearer and post or runner and post.

(4) Where conditions preclude the attachment of bracing to posts, bracing shall be attached to the runners as close to the post as possible.

(5) Bearers shall be installed transversely between posts, and when coupled to the posts, shall have the inboard coupler bear directly on the runner coupler. When the bearers are coupled to the runners, the couplers shall be as close to the posts as possible.

(6) Bearers shall extend beyond the posts and runners, and shall provide full contact with the coupler.

(7) Runners shall be installed along the length of the scaffold, located on both the inside and the outside posts at level heights (when tube and coupler guardrails and midrails are used on outside posts, they may be used in lieu of outside runners).

(8) Runners shall be interlocked on straight runs to form continuous lengths, and shall be coupled to each post. The bottom runners and bearers shall be located as close to the base as possible.

(9) Couplers shall be of a structural metal, such as drop-forged steel, malleable iron, or structural grade aluminum. The use of gray cast iron is prohibited.

(10) Tube and coupler scaffolds over 125 feet in height shall be designed by a registered professional engineer, and shall be constructed and loaded in accordance with such design. Non-mandatory Appendix A to this subpart contains examples of criteria that will enable an employer to comply with design and loading requirements for tube and coupler scaffolds under 125 feet in height.

**(c) Fabricated frame scaffolds (tubular welded frame scaffolds).**

(1) When moving platforms to the next level, the existing platform shall be left undisturbed until the new end frames have been set in place and braced prior to receiving the new platforms.

(2) Frames and panels shall be braced by cross, horizontal, or diagonal braces, or combination thereof, which secure vertical members together laterally. The cross braces shall be of such length as will automatically square and align vertical members so that the erected scaffold is always plumb, level, and square. All brace connections shall be secured.

(3) Frames and panels shall be joined together vertically by coupling or stacking pins or equivalent means.

(4) Where uplift can occur which would displace scaffold end frames or panels, the frames or panels shall be locked together vertically by pins or equivalent means.

(5) Brackets used to support cantilevered loads shall:

(i) Be seated with side-brackets parallel to the frames and end brackets at 90 degrees to the frames;

(ii) Not be bent or twisted from these positions; and

(iii) Be used only to support personnel, unless the scaffold has been designed for other loads by a qualified engineer and built to withstand the tipping forces caused by those other loads being placed on the bracket-supported section of the scaffold.

(6) Scaffolds over 125 feet (38.0) in height above their base plates shall be designed by a registered professional engineer, and shall be constructed and loaded in accordance with such design.

**(w) Mobile scaffolds.**

(1) Scaffolds shall be braced by cross, horizontal, or diagonal braces, or combination thereof, to prevent racking or collapse of the scaffold and to secure vertical members together laterally so as to automatically square and align the vertical members. Scaffolds shall be plumb, level, and squared. All brace connections shall be secured.

(i) Scaffolds constructed of tube and coupler components shall also comply with the requirements of paragraph (b) of this section;

(ii) Scaffolds constructed of fabricated frame components shall also comply with the requirements of paragraph (c) of this section.

(2) Scaffold casters and wheels shall be locked with positive wheel and/or wheel and swivel locks, or equivalent means, to prevent movement of the scaffold while the scaffold is used in a stationary manner.

(3) Manual force used to move the scaffold shall be applied as close to the base as practicable, but not more than 5 feet (1.5m) above the supporting surface.

(4) Power systems used to propel mobile scaffolds shall be designed for such use. Forklifts, trucks, similar motor vehicles or add-on motors shall not be used to propel scaffolds unless the scaffold is designed for such propulsion systems.

(5) Scaffolds shall be stabilized to prevent tipping during movement.

(6) Employees shall not be allowed to ride on scaffolds unless the following conditions exist:

(i) The surface on which the scaffold is being moved is within 3 degrees of level, and free of pits, holes, and obstructions;

(ii) The height to base width ratio of the scaffold during movement is two to one or less, unless the scaffold is designed and constructed to meet or exceed nationally recognized stability test requirements such as those listed in paragraph (x) of Appendix A to this subpart (ANSI/SIA A92.5 and A92.6);

(iii) Outrigger frames, when used, are installed on both sides of the scaffold;

(iv) When power systems are used, the propelling force is applied directly to the wheels, and does not produce a speed in excess of 1 foot per second (.3mps); and

(v) No employee is on any part of the scaffold which extends outward beyond the wheels, casters, or other supports.

(7) Platforms shall not extend outward beyond the base supports of the scaffold unless outrigger frames or equivalent devices are used to ensure stability.

(8) Where leveling of the scaffold is necessary, screw jacks or equivalent means shall be used.

(9) Caster stems and wheel stems shall be pinned or otherwise secured in scaffold legs or adjustment screws.

(10) Before a scaffold is moved, each employee on the scaffold shall be made aware of the move.

**(j) Pump Jack Scaffolds**

(1) Pump jack brackets, braces and accessories shall be fabricated from metal plates and angles. Each pump jack bracket shall have two positive gripping mechanisms to prevent any failure or slippage.

(2) Poles shall be secured to the structure by rigid triangular bracing or equivalent at the bottom, top and other points as necessary. When the pump jack has to pass bracing already installed, an additional brace shall be installed approximately 4 feet (1.2 m) above the brace to be passed, and shall be left in place until the pump jack has been moved and the original brace reinstalled.

(3) When guard rails are used for fall protection, a workbench may be used as the top rail only if it meets all the requirements in paragraphs (g) (4) (ii), (vii), (viii), and (xiii) of Sec. 1926.451

(4) Work benches shall not be used as scaffold platforms.

(5) When poles are made of wood, the pole lumber shall be straight-grained, free of shakes, large loose or dead knots, and other defects which might impair strengths.

(6) When wood poles are constructed of two continuous lengths, they shall be joined together with the seam parallel to the bracket.

(7) When two by fours are spliced to make a pole, mending plates shall be installed at all splices to develop the full strength of the member.

**(k) Ladder jack scaffolds**

(1) Platforms shall not exceed a height of 20 feet (6.1 m).

(2) All ladders used to support ladder jack scaffolds shall meet the requirements of Subpart X of this part - Stairways and Ladder, except that job-made ladders shall not be used to support ladder jack scaffolds.

(3) The ladder jack shall be so designed and constructed that it will bear on the side rails and ladder rungs or on the ladder rungs alone. If bearing on rungs only, the bearing area shall include a length of at least 10 inches (25.4cm) on each rung.

(4) Ladders used to support ladder jacks shall be placed fastened, or equipped with devices to prevent slipping.

(5) Scaffolds platforms shall not be bridged one to another.

**1926.454 TRAINING REQUIREMENTS**

This section supplements and clarifies the requirements of Sec. 1926.21 (b)(2) as these relate to the hazards of work on scaffolds.

(a) The employer shall have each employee who performs work while on a scaffold trained by a person qualified in the subject matter to recognize the hazards associated with the type of scaffold being used and to understand the procedures to control or minimize those hazards. The training shall include the following areas, as applicable:

(1) The nature of any electrical hazards, fall hazards and falling object hazards in the work area;

(2) The correct procedures for dealing with electrical hazards for erecting, maintaining, and disassembling the fall protection systems and falling object protection systems being used;

(3) The proper use of the scaffold and the proper handling of materials on the scaffold;

(4) The maximum intended load and the load-carrying capacities of the scaffolds used; and

(5) Any other pertinent requirements of this subpart.

(b) The employer shall have each employee who is involved in erecting, disassembling, moving, operating, repairing, maintaining, or inspecting a scaffold trained by a competent person to recognize any hazards associated with the work in question. The training shall include the following topics, as applicable:

(1) The nature of scaffold hazards;

(2) The correct procedures for erecting, disassembling, moving, operating, repairing, inspecting, and maintaining the type of scaffold in question.

(3) The design criteria, maximum intended load-carrying capacity and intended use of the scaffold;

(4) Any other pertinent requirements of this subpart.

(c) When the employer has reason to believe that an employee lacks the skill or understanding needed for safe work involving the erection, use or dismantling of scaffolds, the employer shall retrain each such employee so that the requisite proficiency is regained. Retraining is required in at least the following situations:

(1) Where changes at the worksite present a hazard about which an employee has not been previously trained; or

(2) Where changes in the types of scaffolds, fall protection, falling object protection, or other equipment present a hazard about which an employee has not been previously trained; or

(3) Where inadequacies in an affected employee's work involving scaffolds indicate that the employee has not retained the requisite proficiency.